

THANK YOU FOR VOTING TEXECOM

INSTALLATION MANUAL

Premier 24

Security Control Panels

Issue 2



Texecom
www.texe.com

Contents

1. System Overview	4	6.1 Zone Setup	31
System Architecture	4	Zone Types	32
Control Panel	4	Zone Attributes 1	33
Remote Keypads.....	4	Zone Attributes 2	33
Zone Expanders.....	5	Attributes for Moment or Latch Keys	34
Output Expander.....	5	Zone Text.....	34
Communicators	5	Zone Wiring Type.....	34
Other Devices	5	DD 243:2002.....	34
2. Installation	6	6.2 Arming Options.....	35
Installation Sequence.....	6	Timers	35
Control Panel	6	Arming Modes.....	36
Connecting AC Mains.....	9	Options.....	36
Connecting Batteries.....	9	6.3 Global Options	39
Connecting Devices to the Network	10	System Timers	39
Remote Keypads.....	12	System Config.	40
4XP Zone Expander	13	System Options	42
8XE Zone Expander.....	13	Monitor Hardware	42
8XP Zone Expander	14	Control Timers	43
24XID Zone Expander	15	System Text	43
OP16 Output Expander.....	16	Speaker Tones.....	44
Zone Connections	17	6.4 Keypad Setup.....	45
Auxiliary Tamper Connections.....	18	Keypad Zone Mapping	46
Speaker Connections	18	Keypad Options	46
External Sounder Connections.....	18	Keypad Speaker Volume.....	46
Panel Outputs 1 - 6 and PG1	19	Keypad Sounder Options.....	46
Plug-on Digimodems	20	6.5 Expander Setup	47
RP9 Radio-Pad	21	Expander Auxiliary Input.....	48
GSM Module	21	Expander Speaker Volume.....	48
PC-Com	21	Expander Sounder Options.....	48
UNI-Com.....	21	6.6 System Outputs	49
PRINT-Com.....	21	Available Outputs	50
GSM-Com	22	Programming Outputs.....	50
NET-Com	22	Output Group - Not Used	50
Connecting a Computer	22	Output Group - System	50
Connecting a Printer.....	22	Output Group - Alarm	51
3. Commissioning and Troubleshooting	23	Output Group - Zone	53
Commissioning.....	23	Output Attributes	53
Trouble-Shooting.....	23	Custom Output (PGM5-8).....	53
Reset and Service Messages.....	25	6.7 UDL/Digi Options	54
4. Factory Defaults	26	Reset Digi.....	54
5. The Programming Menu	28	Start Test Call	54
Introduction.....	28	Program Digi.....	55
6. Programming the Control Panel.....	30	Digi Options	58
Introduction.....	30	UDL Options.....	59
Log Off Engineer.....	30	Radio/SMS Options	61
Reset the Engineers Code (User 00).....	30	Com Port Setup	61
		Zone Alarm Reporting Codes	62

- 6.8 Setup Users.....67**
 - Adding New Users to the System 68
 - Programming New Users..... 68
 - User Types 68
 - User Options 69
 - User Name Text..... 69
 - Programming Proximity TAGS 69
 - Deleting User Codes..... 69
 - Available Options..... 70
- 6.9 Engineer Utilities 71**
 - View Event Log..... 71
 - Do Bell Test 73
 - Do Walk Test 73
 - View Zone Status 74
 - View Version No 74
 - Confirm Devices..... 74
 - View RKP Status..... 74
 - Check Exp. Status..... 75
 - Set System Time 75
 - Set System Date..... 75
 - Change Eng. Code..... 75
- 6.10 Programming Part Arms 76**
 - Alter Part Arms 76
- 7. Specifications 77**
 - Control Panel 77
 - Remote Keypads..... 78
 - Zone Expanders 78
 - Output Expanders 79
 - Communicators..... 79
 - Standards 80
 - Warranty 80
- 8. Quick Reference Guide 82**

- 1. System Overview**
- 2. Installation**
- 3. Commissioning & Troubleshooting**
- 4. Factory Defaults**
- 5. The Programming Menu**
- 6. Programming the Control Panel**
 - 6.1. Zone Setup**
 - 6.2. Area Programming**
 - 6.3. Global Options**
 - 6.4. Keypad Setup**
 - 6.5. Expander Setup**
 - 6.6. Output Setup**
 - 6.7. UDL/Digi Options**
 - 6.8. Setup Users**
 - 6.9. Engineer Utils**
 - 6.10. Programming Part Arms**
- 7. Specifications**
- 8. Quick Reference Guide**

1. System Overview

System Architecture

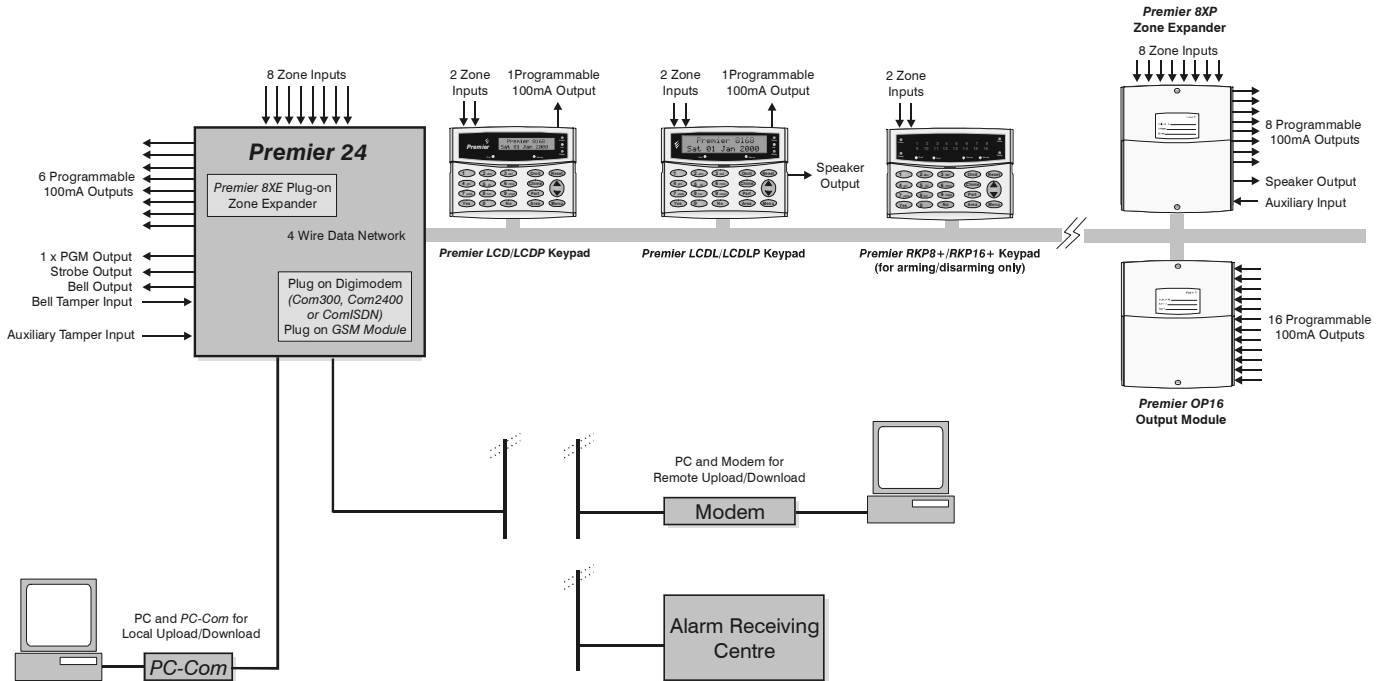

Control Panel

Premier 24

- 8 fully programmable Single Pole + Global Tamper or End Of Line zones
- Expandable to 24 zones via keypads and zone expanders
- Up to 4 keypads
- Up to 2 expanders (2 remote or 1 local and 1 remote)
- Up to 1 output module
- 4-wire data network (standard 7/0.2 alarm cable)
- Full arm plus 3 part arms
- Shunt group
- 16 programmable User codes
- 500 Event Log (time & date stamped)
- 16 character zone text
- 9 programmable outputs (100mA each)
- Facility for Plug-on Digimodem (*Com300*, *Com2400* or *ComISDN*)
- Facility for Plug-on *GSM Module*
- *PC-Com*/printer port

Remote Keypads

Premier LCD

- 32 character text display
- 2 fully programmable DP or EOL zones
- 1 fully programmable output (100mA -ve applied)
- Fully adjustable back-lighting, normally bright, dim or off, changing to bright during entry or following a key press
- Built in piezo sounder
- Programmable 'Info.' LED

Premier LCDL

ALL the features of the *Premier LCD* plus:

- Larger 32 character text display
- Speaker output

Premier LCDP

- *LCD* keypad with a built in Proximity Tag Reader

Premier LCDLP

- *LCDL* keypad with a built in Proximity Tag Reader

Premier RKP8/16Plus

- LED Arming keypad
- 2 fully programmable EOL zones
- CANNOT be used for Programming

Zone Expanders

Premier 4XP

- 4 fully programmable DP or EOL zones
- 2 fully programmable outputs (100mA -ve applied each)
- Remotely wired unit

Premier 8XE

- 8 fully programmable SP or EOL zones
- Plug-on unit

Premier 8XP

- 8 fully programmable DP or EOL zones
- 8 fully programmable outputs (100mA -ve applied each)
- Speaker output
- Programmable auxiliary input
- Remotely wired unit

Premier 24IXD

- 1 loop x 24 fully programmable iD zones
- iD biscuit technology
- Plug-on unit for *Premier 24* only

“iD” is a registered trade mark of Chloride Safety System Limited.

Output Expander

Premier OP16

- 16 fully programmable outputs (100mA each)
- 1 fault output (100mA -ve applied)
- Can be connected to relays and internal sounders

Premier RM8 Relay Module

- Plug-on relay card (RedCARE footprint)
- 8 separate inputs for stand alone operation
- 8 x 3Amp relay outputs (n/o, n/c, com)
- Output ‘ON’ LED indication

Communicators

Com300

- 8 channel digital communicator supporting Fast Format, Contact ID, SIA Level II and EasyCom Pager protocols
- 300-baud modem for remote uploading and downloading using the *Wintex UDL* software and a PC
- For use with an analogue telephone line (REN = 1)

Com2400

- 8 channel digital communicator supporting Fast Format, Contact ID, SIA Level II and EasyCom Pager and SMS Messaging protocols
- 2400-baud modem for remote uploading and downloading using the *Wintex UDL* software and a PC
- Sends SMS text messages to mobile phones
- For use with an analogue telephone line (REN = 1)

ComISDN

- 8 channel digital communicator supporting Fast Format, Contact ID, SIA Level II and EasyCom Pager protocols
- 300-baud (analogue) or 19200-baud (digital) Modem for remote uploading and downloading using the *Wintex UDL* software and a PC
- For use with an ISDN telephone line

RP9 Radio-Pad

- 8 channel Paknet radio communicator supporting Fast Format and Contact ID protocols
- 4800-baud modem for remote uploading and downloading using the *Wintex UDL* software and a PC

GSM Module

- True GSM telephone line backup
- Sends SMS text messages to mobile phones
- Arm, Disarm, Reset the alarm, turn outputs on and off, omit zones and send messages to the control panel using SMS text messages
- 9600-baud modem for remote uploading and downloading using the *Wintex UDL* software and a PC

Other Devices

PC-Com/USB-Com

- For connecting a PC to the control panel allowing local uploading and downloading using *Wintex UDL* software

UNI-Com

- For connecting a serial device i.e. PC modem or mobile phone to the control panel

PRINT-Com

- For connecting a serial printer to the control panel

RPD-Com

- For connecting a *RP9 Radio-Pad* to the control panel

GSM-Com

- For connecting a *GSM Module* to the control panel

NET-Com

- For connecting a control panel to a TCP/IP network

2. Installation

Installation Sequence

Before attempting to install the alarm system, read this section. Once you have an overall understanding of the installation sequence, carefully work through each step.

1: Design the Layout

Make a rough sketch of the premises to get an idea of where the alarm detection devices, keypads, zone expanders etc. are to be located.

2: Mounting the Panel

The control panel should be mounted in a dry area close to an unswitched AC power source and the incoming telephone line (if using the digimodem).



NOTE You must complete all wiring before connecting the battery or applying AC mains to the control panel.

3: Install the Keypads and Zone Expanders

Mount and connect the keypads, zone expanders and output modules to the control panel (see page 10 for details).

4: Install the Alarm Detection Devices

Install the detection devices, PIR's, Contacts, PA Buttons etc. and connect them to the control panel (see page 17 for details).

5: Install the External Sounder

Install the external sounder and connect to the control panel (see page 18 for wiring details).

6: Other Wiring

Complete all other wiring including speakers, telephone line and output connections etc. (see pages 18 - 20 for details).

7: Applying Power to the Control Panel

Once steps 1 to 6 are completed, power can be applied to the control panel.

When applying power for the first time, the factory default settings must be loaded (see page 23 for details). Power should always be connected in the following order:

- Connect the red battery lead to the positive terminal of the battery and then connect the black battery lead to the negative terminal



NOTE The panel will only become 'live' when the AC Mains is connected or the 'Battery Kick-start' button is pressed.

- Connect the AC mains

For a complete list of factory default settings, see page 26.

8: Programming the control panel

Please refer to section 5 for instruction on programming the control panel.

9: Testing the System

Test the system thoroughly to ensure that all features and functions operate as required (see page 73 for details).

Control Panel

Mounting

Mount the control panel on a flat, plumb wall using at least three screws of appropriate size.



NOTE It is essential to ensure that none of the fixing slots or cable entries are accessible after fixing.

Mains cabling must be secured (e.g. with a cable tie) to one of the anchor points provided.

Wiring the Control Panel

WARNING: ELECTRICITY CAN KILL

BEFORE connecting the control panel ALWAYS disconnect the supply at the consumer unit. If in ANY doubt consult a qualified electrician.



NOTE ONLY connect the mains supply to the mains terminal block, NEVER connect the mains supply directly to the PCB.

ALWAYS refer to National Wiring Regulations when conducting installation.

An appropriate and readily accessible disconnection device (e.g. an unswitched fused spur) MUST be provided as part of the installation.

The disconnection device must NOT be fitted in a flexible cord.

Where identification of the neutral in the mains supply is NOT possible a two-pole disconnection device MUST be used.

The building mains supply MUST incorporate appropriate short-circuit backup protection (e.g. a fuse or circuit breaker) of High Breaking Capacity (HBC, at least 1500A).

Use mains cable of adequate carrying capacity for the rated current (i.e. at least 0.75mm²).

Control Panel Layout

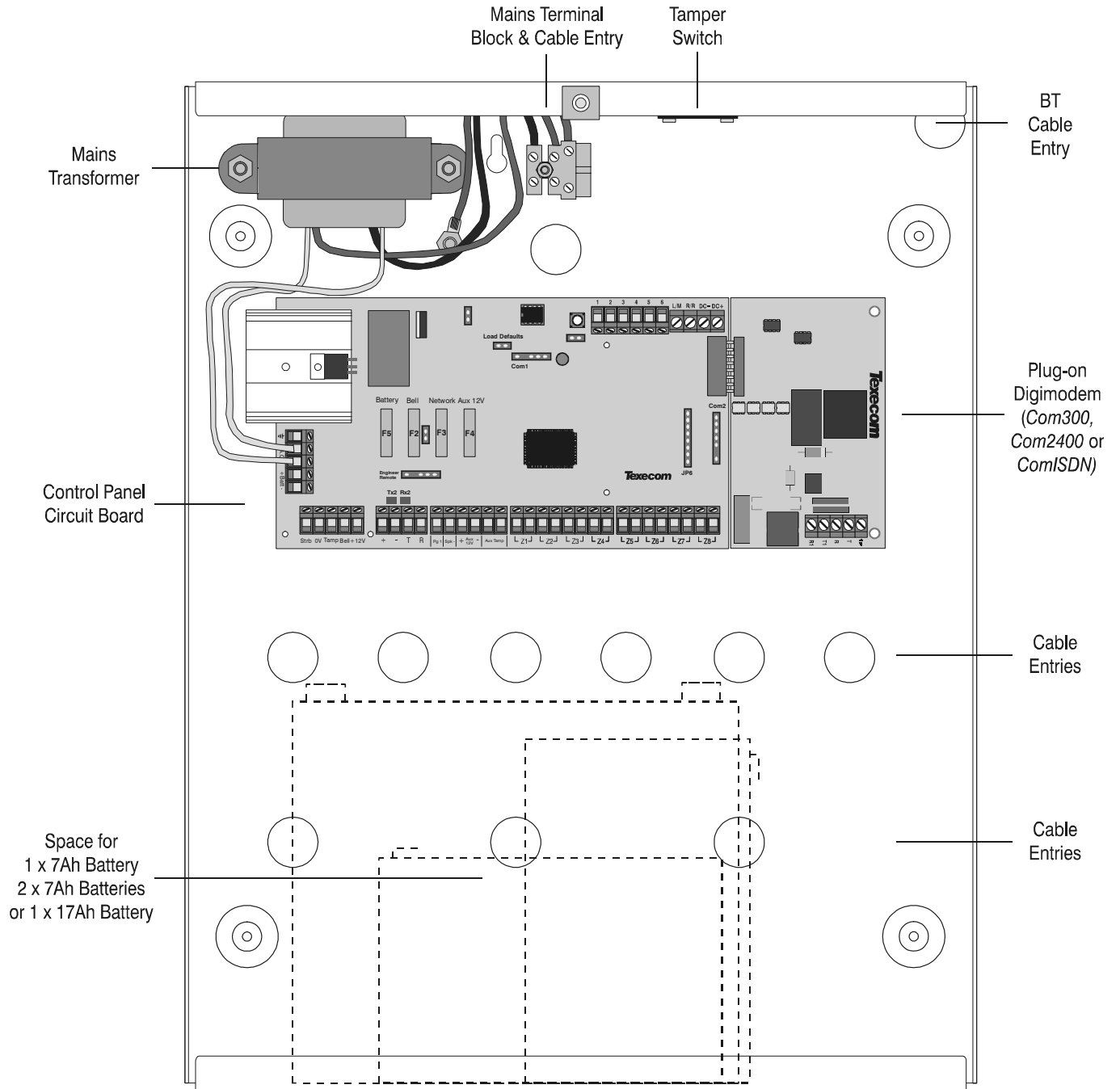

Control Panel PCB Layout

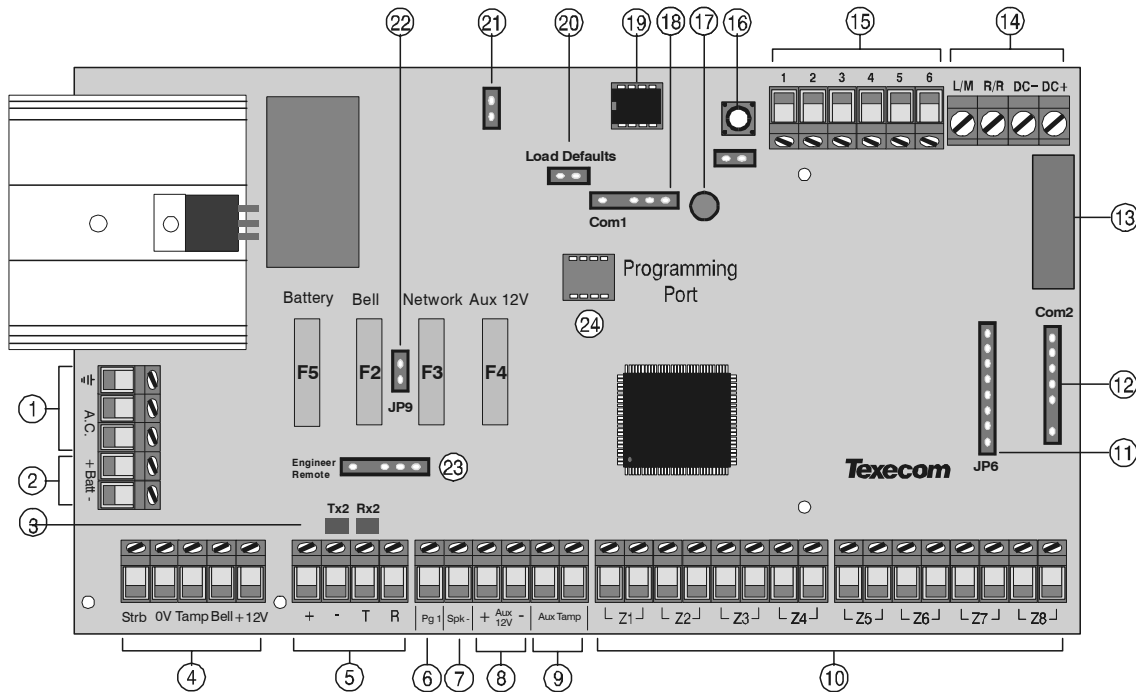

1: AC Input

Connected to the 16.5V transformer.

⚠ DO NOT CONNECT THE MAINS SUPPLY TO THE AC INPUT TERMINALS ON THE PCB.

2: Battery Connections

A 12V rechargeable battery must be connected to these terminals in order to provide continuous system operation in the event of an AC Mains failure (see page 9 for details).

3: Network Data Indicators

The red LED indicates that data is flowing out of the control panel and normally flashes very quickly. The green LED indicates that data is flowing into the control panel and normally flashes slowly, the green LED flashes faster as more devices are connected (see page 10 for details).

4: External Sounder Connections

These terminals are used for connecting to an external sounder unit and is protected by a 900mA PTC – F2 (see page 18 for wiring details).

5: Network Connections

The Network provides connection for the keypads and zone expander. The '+' and '-' terminals provide power (protected by a 900mA PTC – F3) whilst the 'T' transmits data and 'R' receives data (see page 10 for wiring details).

6: PG1

PG1 is a low current (100mA '-ve' applied) output (see page 19 for wiring details). The output is also fully programmable (see page 50 for programming details).

7: SPK- Loudspeaker Connection

These terminals can be used for connecting up to one 16Ω or two 8Ω loudspeakers (see page 18 for wiring details).

8: Auxiliary 12V Power

These terminals are for connecting devices that require 12V power (protected by a 900mA PTC - F4).

9: Auxiliary Tamper Connections

These terminals can be used for monitoring the box tamper of auxiliary devices such as power supplies etc. (see page 17 for wiring details).

10: Programmable Zones 1 - 8

These terminals provide the connections for the 8 zones (see page 17 for wiring details). Each zone is also fully programmable (see page 31 for programming details).

11: Expansion Port

The expansion port is used for plugging on a local zone expander (see page 13 for details).

12: Communication Port 2

Com Port 2 is a serial communications port and can be used for connecting a *GSM Module*.

13: Plug-on Digimodem Connections

This socket provides connection for a *Com300*, *Com2400* or *ComISDN* digimodem (see page 20 for details).

14: Digicom Power & Inputs

These terminals provide +12V power (unfused), a remote reset input and a line fault input and would normally be used when connecting a stand-alone communicator to the control panel (see page 19 for wiring details).

15: Panel Outputs

Outputs 1 to 6 are low current (100mA '-ve' applied) and would normally be used when connecting a stand-alone communicator to the control panel (see page 19 for wiring details). Each output is also fully programmable (see page 50 for programming details).

16: Box Tamper Connection

The box tamper micro switch is connected here. The micro switch provides tamper protection for the main control panel in case of unauthorised access. To disable the box tamper, remove the micro switch lead and fit a jumper link across the two pins instead.

17: Indicator/Power Light

ON to indicated AC Mains power is present and flashes to indicate that there is an AC Mains failure, also flashes when the plug-on communicator is active.

18: Communication Port 1

Com Port 1 is a serial communications port and can be used for connecting a PC running *Wintex*, a *Com2400*, a serial PC modem, a *GSM Module* or a *NET-Com Network Card*.

19: NVM

All system programming data and the event log is stored in this removable non-volatile memory devices.

20: Load Defaults pins

Short these pins whilst applying power to the control panel to load the factory default settings. Short and hold these pins for 5 seconds with power already on the panel to restore just the Engineer code to the factory setting of

① ② ③ ④



NOTE Loading the factory default can take up to 30 seconds to complete.

Loading defaults will only be possible if the NVM has not been locked (see page 40 for details).

For a complete list of factory defaults, see page 26.

21: Battery Kick-start pins

When powering up the panel without AC Mains present, these pins must be shorted in order to connect the battery.

22: Bell Power Disconnection Jumper (JP9)

A jumper link should be fitted here to ensure the correct operation of the external sounder, removal of this jumper will isolate the 12V power.

23: Engineers Keypad

A portable Engineers keypad can be plugged on here to allow easier access for programming and testing.



NOTE When using a keypad as an Engineers keypad, the address must be set to '10' (see page 12 for details).

The keypad zones and cover tamper will not be monitored by the system.

24: Programming Port

A flash ROM programmer can be connected here to allow programming of the control panes firmware.

F2 - F5: Protection Fuses

The following Electronic Fuses are provided for protection:

- F5 Battery (1.6A)
- F4 Auxiliary 12V Power fuse (900mA)
- F2 Bell/Strobe (900mA)
- F3 Data Network (900mA)

Connecting AC Mains

The AC Mains supply is connected to a 3 way 'Euro Type' fused terminal block, which is fitted with a 125mA or 500mA fuse.



NOTE All other wiring MUST be carried out before AC mains is connected to the control panel.

After connecting the AC Mains, fit the mains cover, this can be found in the spares bag.

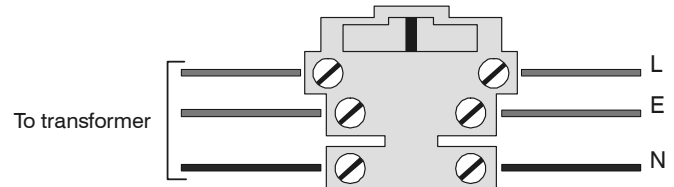
**Connecting Batteries**

One or two 12V 7Ah batteries or one 12V 17Ah battery can be fitted inside the control panel (metal housing) to provide continued operation in the event of an AC mains failure.



NOTE All other wiring MUST be carried out before the battery is connected to the control panel.

Connect the red battery lead to the positive terminal of the battery and then connect the black battery lead to the negative terminal.



NOTE The panel will only become 'live' when the AC Mains is connected or the 'Battery Kick-start' button is pressed.



OR

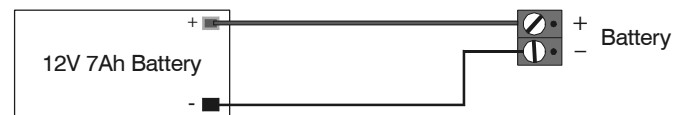

OR

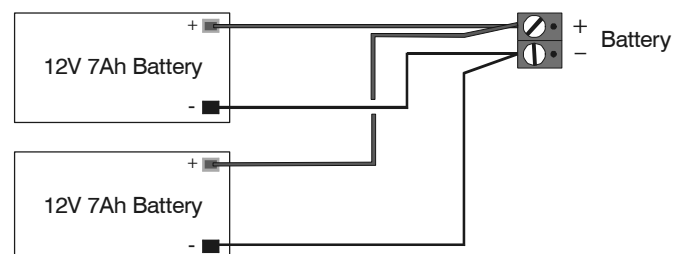

Connecting Devices to the Network

Before connecting keypads, zone expanders and output modules, isolate ALL power from the control panel (AC Mains & Battery). Do not continue if there is still power present on the control panel.



Connecting devices with power still present on the control panel may damage the device or control panel and invalidate any warranty.

Keypads, zone expanders and output modules are all connected to the same network terminals located at the bottom left hand corner of the control panel and may be connected serially (daisy chain), in parallel (star) or any combination of the two (see Figure 1, page 11 for wiring details).



A maximum of 2 zone expanders, 4 keypads and 1 output module can be connected to the network.

Whenever new devices are connected to the network, they must be confirmed onto the system using the 'Confirm Devices' menu option (see page 74 for details).

Wiring the Network

The networks are made up of four terminals incorporating power and data. To ensure correct operation, all four terminals on the device must be connected to the corresponding terminals on the control panel, or previous device (see Figure 1, page 11 for wiring details). The table below shows each terminal and its description:

Terminal	Description
+	+12V Supply
-	0V Supply
T	Transmit Data
R	Receive Data

Devices can be connected using 4-core cable. However, it is recommended that 6 or 8-core cable is used as the spare cores can be used to 'Double Up' on the power connections if needed.



Standard 7/0.2 alarm cable can be used for most installations. However, under certain conditions it may be necessary to use screened cable.

Cable Distances

The maximum recommended distance for devices when using standard 7/0.2 alarm cable is:

- 250m for each branch when using the star (parallel) configuration
- When using a daisy chain (series) configuration the maximum distance will depend on the number of devices connected on the chain. The more devices that are connected, the shorter the distance to the last device (this is due to voltage drop in the cable)

Whichever method of wiring configuration is used, ensure that the voltage between the '+' and '-' terminals at each device is no lower than 10.0V when the system is running on the standby battery.

The table below shows maximum cable runs when one keypad or expander is installed using standard 7/0.2 alarm cable with various loads:

Configuration	Max. Cable Run
1. Keypad + 2 PIR's @15mA	250m
2. Expander + 2 PIR's @15mA	250m
3. Expander + 8 PIR's @15mA	100m
4. As No. 3 + 16Ω Speaker	30m

Distances of up to 1km can be achieved between the control panel and a device. However, a power supply must be installed close to the device to power it locally, this will help to overcome voltage drop caused by the long cable run.

Overcoming Voltage Drop

There are several ways to overcome voltage drop:

- Use thicker lower resistance cable. Standard 7/0.2 alarm cable has a resistance of 8Ω per 100m
- Double up on the power connections – this will require using a 6 or 8-core cable rather than a 4-core cable
- Install a power supply to power the device locally, remember to common the two negative connections

Installing a Power Supply

When a power supply is installed, the 0V connections on the power supply must be connected through to 0V on the control panel and the +12V connection between the control panel and the device must be disconnected (see Figure 2, on page 11 for wiring details).

Network Diagnostics

Each network has two LED's to indicate data flow. The red LED indicates data flowing out of the 'T' terminal and the green LED indicates data flowing into the 'R' terminal. The table below shows each LED status and its meaning:

LED Status	'T' Wire OUT	'T' Wire IN
Red LED Flashing	Normal	Normal
Red LED On	Panel Fault	Cable Short
Red LED Off	Panel Fault	Panel Fault

LED Status	'R' Wire OUT	'R' Wire IN
Green LED Flashing	Panel Fault	Normal
Green LED On	Panel Fault	Cable Short
Green LED Off	Normal	No Data From Devices



The LED's are provided as an aid for fault finding and therefore should not be completely relied upon to indicate that there is a fault.

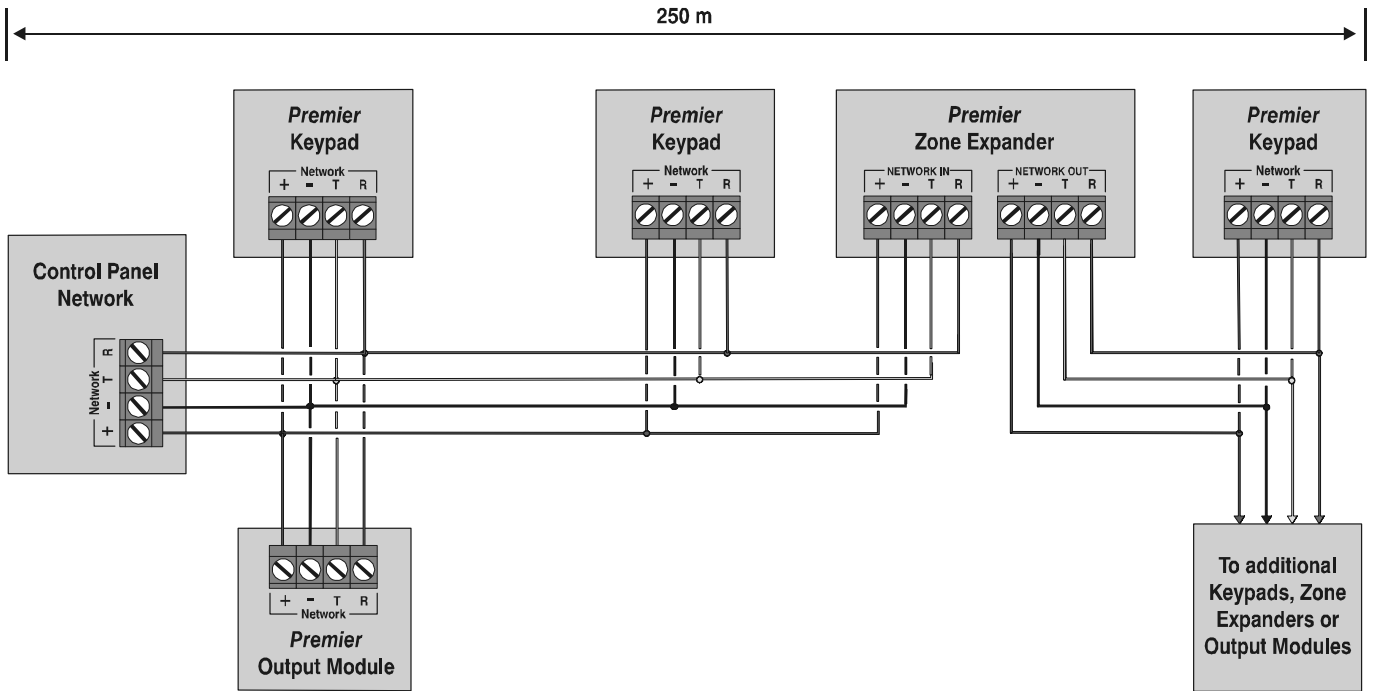

Figure 1: Network Connections (250m without additional power supply).

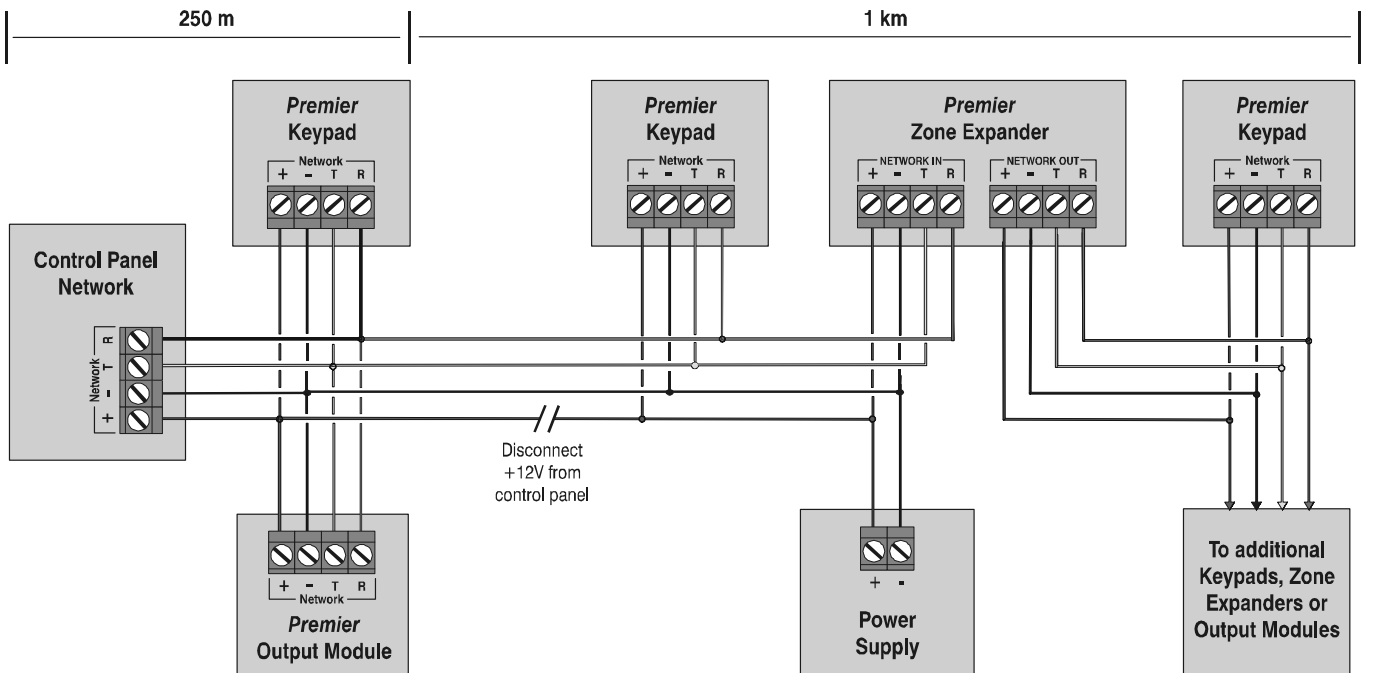

Figure 2: Network Connections (1km with additional power supply).

Remote Keypads

The Premier LCD, LCDL, LCDP and LCDLP keypads all have:

- 2 fully programmable zones
- 1 fully programmable -ve applied output
- A fully programmable LED indicator ('Info.' LED)

In addition the LCDL and LCDLP keypads have:

- A fully adjustable speaker output

The LCDP and LCDLP keypads also have:

- A built in Proximity Tag/Card reader

The RKP8/16Plus keypads both have:

- Full LED Indication and 2 fully programmable zones

Keypad Layout

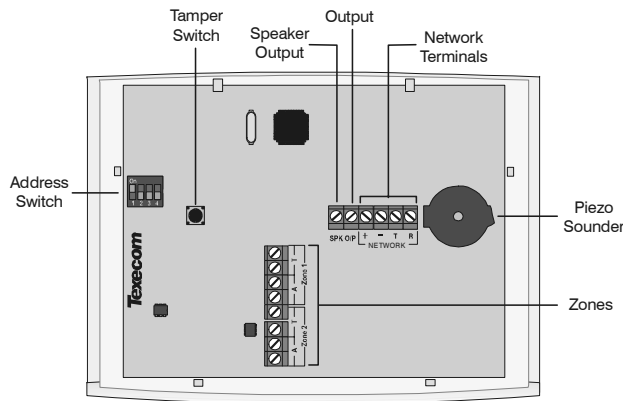

Connecting Keypads

Keypads are connected to the network terminals located at the bottom left hand corner of the control panel (see pages 10 & 11 for connection details).

Keypad Addressing

Each keypad must be assigned a different address using the DIL switches located on the left hand side of the PCB. The table below shows the keypad addressing:

Address	DIL 1	DIL 2	DIL 3	DIL 4	
1	On or off	Off	Off	Off	
2	Off	On	Off	Off	
3	Off	Off	On	Off	
4	Off	Off	Off	On	
Engineers	On	On	On	On	

NOTE Never set two keypads on the same network to the same address.

When using a keypad as an Engineer's keypad, the DIL switches must all be 'On'.

Zone Numbering

The table below shows the zone allocation when the keypads are installed:

Address	Zones (Network 1)	Zones (Network 2)
1	Unmapped	Unmapped
2	Unmapped	Unmapped
3	Unmapped	Unmapped
4	Unmapped	Unmapped

NOTE The zones inside the keypads are not seen by the system until they have been mapped to a zone number (see page 46 for details).

Keypad Zones

The keypad has two programmable zones (see page 17 for wiring details). Each zone is also fully programmable (see page 31 for programming details).

Keypad Output

The remote keypad has one programmable output, which can be used to drive auxiliary devices such as LED's, sounders or relays etc. Wire as per Panel Outputs shown on page 19 (see page 48 for programming details). The electrical characteristics for the output are shown below:

Output	Max Current	Type
1	100mA	Switched -ve

Keypad Speaker Output (LCDL/LCDLP Only)

The Premier LCDL and Premier LCDLP keypads have an output that can be used for driving up to one 16Ω or two 8Ω loudspeakers (see page 18 for wiring details).

NOTE The speaker volume is also fully adjustable (see page 46 for details).

Programmable 'Info.' LED

The 'Info.' LED on the front of the keypad can be programmed to mimic the keypad output or show the armed status of alarm (see page 46 for details).

Adjustable Backlighting

To adjust the keypad backlighting press the **YES** key for 5 seconds, then with the **YES** key still pressed use to increase or decrease the backlighting until the required brightness is achieved, then release both keys.

NOTE The backlight can only be adjusted when the keypad is not in a menu.

Keypad Lid Tamper

The lid tamper of each keypad can be disabled if required using the relevant keypad option in the Keypad Setup menu (see page 46 for details).

4XP Zone Expander

This column is intentionally blank.

8XE Zone Expander

The Premier 8XP Zone Expander has:

- 8 fully programmable zones
- Aux 12V Output

Expander Layout

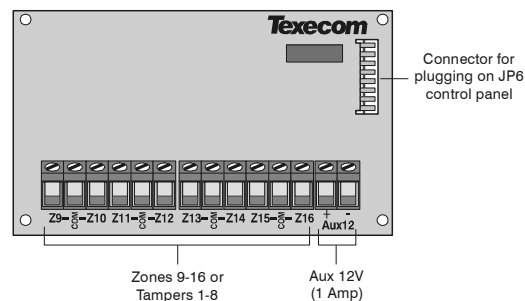

Connecting Expanders

The 8XE local zone expander plugs directly on to the terminals located on the right hand side of the control panel (see below for details). To install the local zone expander proceed as follows:

1. Ensure that all power is removed from the control panel (mains and battery) before attempting to fit the expander.
2. Push the four support pillars (supplied) into the four locating holes on the control panel PCB.
3. Align the local expander connector with the 8 way plug (JP6) on the control panel. Push expander into place, ensuring that all four pillars clip into the four locating holes on the local expander.

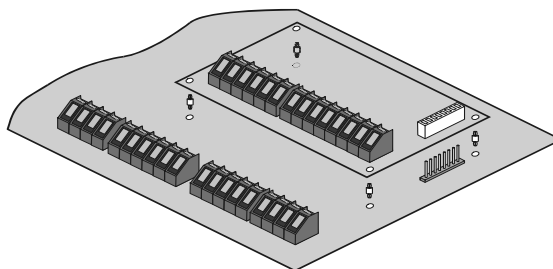

Zone Numbering

The table below shows the zone allocation when the expanders are installed:

Configuration	Panel Zones	Expander Zones
8XE = Zones	1 to 8	9 to 16
8XE = Tamper	1 to 8	Tampers 1 to 8

Expander Zones

The expander has eight programmable zones (see page 17 for wiring details). Each zone is also fully programmable (see page 31 for programming details).

8XP Zone Expander

The Premier 8XP Zone Expander has:

- 8 fully programmable zones
- 8 fully programmable –ve applied outputs
- 1 programmable auxiliary input
- A fully adjustable speaker output

Expander Layout

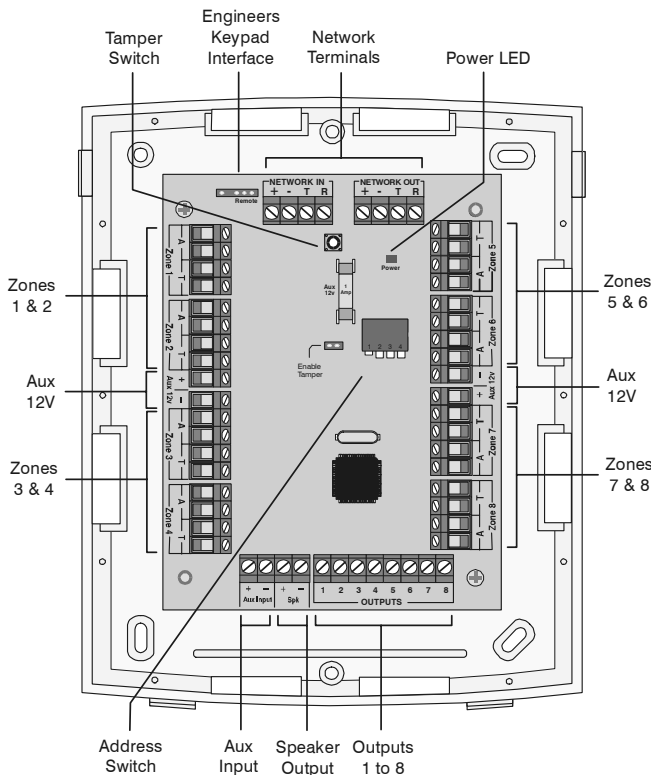

Connecting Expanders

Expanders are connected to the network terminals located at the bottom left hand corner of the control panel (see pages 10 & 11 for connection details).

Expander Addressing

Each Expander must be assigned a different address using the DIL switches located in the centre of the PCB. The table below shows the expander addressing:

Address	DIL 1	DIL 2	DIL 3	DIL 4	
1	On or off	Off	Off	Off	
2	Off	On	Off	Off	

NOTE Never set two expanders on the same network to the same address.

Zone Numbering

The table below shows the zone allocation when the expanders are installed:

Address	Zones
1	9 - 16
2	17 - 24

Expander Zones

The expander has eight programmable zones (see page 17 for wiring details). Each zone is also fully programmable (see page 31 for programming details).

NOTE When using an 8XP Zone Expander, the wiring configuration must always be selected as 'Double EOL' even if wired as Double Pole.

Expander Auxiliary Input

The expander has one programmable input. This auxiliary input can be used to monitor auxiliary devices such as tamper loops etc. Wire as per Aux Tamper shown on page 18 (see page 48 for programming details). The system will respond as follows:

Input Status	System Response
0V Applied	Input Secure
0V Removed	Input Active

NOTE For further details on how the input status affects the system please refer to page 48.

Expander Outputs

The zone expander has eight programmable outputs, which can be used to drive auxiliary devices such as LED's, sounders or relays etc. Wire as per Panel Outputs shown on page 19 (see page 48 for programming details). The electrical characteristics for the outputs are shown below:

Outputs	Max Current	Type
1 to 8	100mA	Switched -ve

Expander Speaker Output

The expander has an output that can be used for driving up to one 16Ω or two 8Ω loudspeakers (see page 18 for wiring details).

Expander Lid Tamper

The lid tamper of each expander can be disabled if required by fitting a jumper link across the centre and right hand pins of the 'Enable Tamper' pins (JP2) leaving the left hand pin free. These pins are located to the left of the address DIL switch just beneath the fuse.

24XID Zone Expander

One 24XID expander can be connected to the Premier 24 to provide 1 ID loop supporting up to 24 biscuits.

Installation

Before connecting the 24XID expander module, isolate ALL power from the control panel (AC mains and battery), do not continue if there is still power present on the control panel.

1. Plug the expander onto the control panel, see 24XID installation manual for details.
2. Connect the iD devices to the expander module, see "iD Connections".
3. Reapply power to the control panel and program the necessary options on the panel see 24XID installation manual for details.

iD Connections

Each iD biscuit is connected across a two-wire detector loop. Apart from observing the correct polarity, any wiring configuration can be used, as shown in the diagram below:

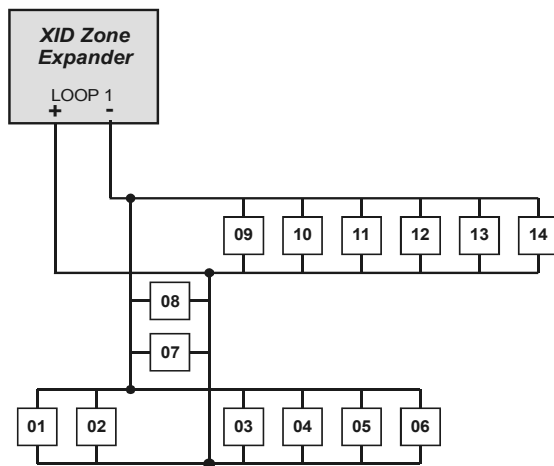

Cabling Considerations

The iD loop can be wired using standard 4-core alarm cable, this allows 2 cores to be used for the iD biscuit and 2 cores for supplying 12V power for PIR's etc.

The number of biscuits that can be connected per cable run is determined by the impedance of the cable used. Standard 4-core alarm cable (7/0.2mm) has a resistance of approximately 8 Ohms per 100 metres. The following table shows the maximum number of biscuits that can be connected at the end of a single cable run using standard 4-core alarm cable:

Cable Length	Maximum Number of Biscuits
100m	30
200m	15
400m	7
800m	3

If a different type of cable is used, the distances should be re-calculated. e.g., if 7/0.4mm cable is used, a single run of 200m would support 30 devices on the end as the resistance of the cable is halved.

When installing the iD loop it is usually more practical to run several cables from the expander module to the different areas of protection. This effectively reduces any distance problems and makes fault finding much easier.

To reduce the risk of induced interference and wherever possible, cables should not be positioned along side mains power, telephone or other data transmission cables, or run within the same ducting or trunking as any other cables.

The wiring for the system's internal sounders (loudspeakers) should not be connected in the same multi-core as the iD loop.

Biscuit Connections

Each iD biscuit is identified by its own number 01 to 30 and contains its own internal sensor that is continuously monitored by the expander module. The diagram below shows the connections to the biscuit for monitoring both tamper and alarm contacts.

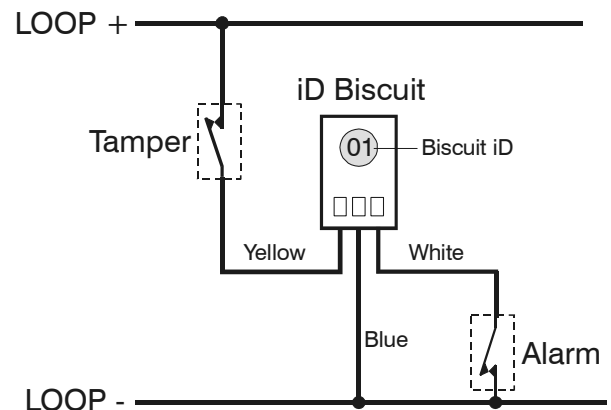

When the tamper switch is opened, the iD biscuit is taken offline and a tamper condition is generated by the control panel. If the alarm switch is opened the biscuit's internal sensor changes state and the control panel will see this as an active condition and will respond as appropriate.

The diagram below shows the typical wiring of a biscuit to a standard PIR.

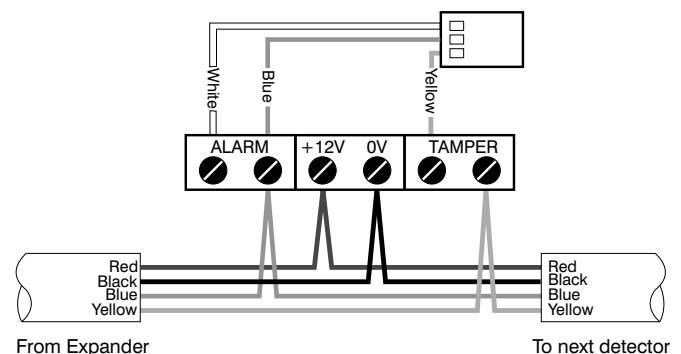

"iD" is a registered trade mark of Chloride Safety System Limited.

OP16 Output Expander

A maximum of 1 output module can be connected to the network along with keypads and zone expanders.

The Premier OP16 output module can be set up to mimic the outputs of zone expanders.

NOTE In order for an output module to mimic zone expander outputs, the output module must be addressed the same as the zone expander that it is mimicking.

Output Module Layout

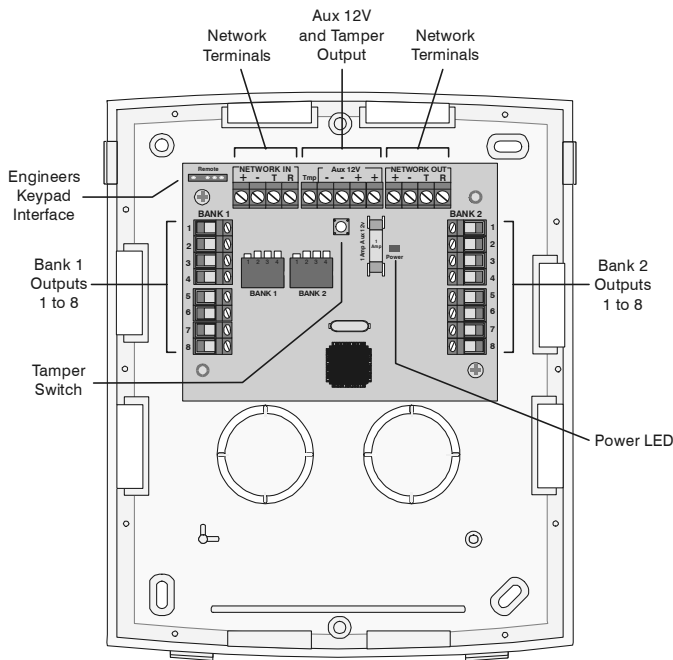

Connecting Output Modules

Output modules are connected to the network terminals located at the bottom left hand corner of the control panel (see pages 10 & 11 for connection details).

Output Module Addressing

Each output module must be assigned a different address using the DIL switches located in the centre of the PCB.

NOTE Bank 1 switch sets the address of the device that Bank 1 outputs 1 to 8 will mimic.

NOTE Bank 2 switch sets the address of the device that Bank 2 outputs 1 to 8 will mimic.

The table below shows the output module addressing:

Address	DIL 1	DIL 2	DIL 3	DIL 4	
1	On or off	Off	Off	Off	
2	Off	On	Off	Off	

Output Module Numbering

The table below shows the output allocation when the output modules are installed:

Address	Outputs
1	Expander 1, 1 - 8
2	Expander 2, 1 - 8

Outputs

The output module has 16 programmable outputs, which can be used to drive auxiliary devices such as LED's, sounders or relays etc. Wire as per Panel Outputs shown on page 19 (see page 48 for programming details). The electrical characteristics for the outputs are shown below:

Bank	Outputs	Max Current	Type
1	1 to 8	100mA	Switched -ve
2	1 to 8	100mA	Switched -ve

Tamper Output

The tamper switch on the output module is connected to the tamper output at the top of the module. If monitoring of the lid tamper is required, this output must be connected to a suitable input on the control panel or zone expander.

Zone Connections

The Premier 24 has 8 zones on board the control panel that can be wired as either 'Single Pole' or 'End Of Line'.

NOTE Any zones that are not being used must be linked out or programmed as 'Not Used' (see page 31 for details).

Single Pole

Use this wiring configuration when connecting normally closed or normally open detection devices to the zone using 2-Wires.

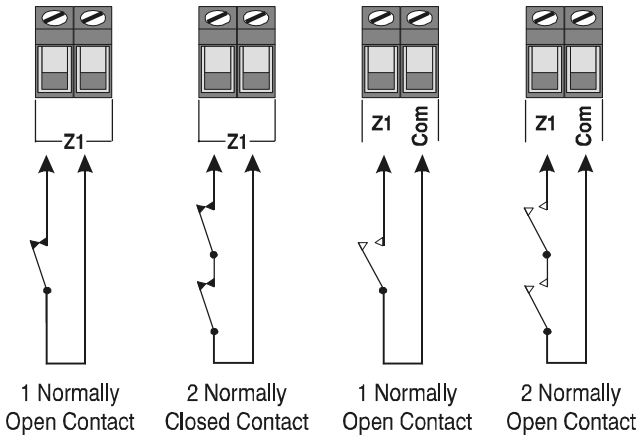

NOTE When using this configuration the tampers must be wired to the Aux tamper input (see page 18 for details).

Double Pole

Use this wiring configuration when connecting normally closed or normally open detection devices to the zone using 4-Wires.

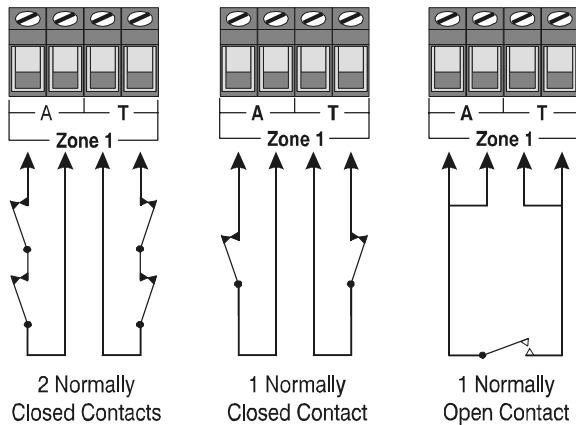

NOTE When using this configuration, no more than 10 detectors can be connected to each zone.

When wiring device as normally open contacts as above, ensure that system Config. option 21 is set to 'Zone Short = Active' (see page 41 for details).

When wiring double pole (4-wires) to a keypad or zone expander, the wiring configuration must always be programmed as 'Double EOL'.

End Of Line

Use this wiring configuration when connecting normally closed or normally open detection devices to the zone using 2-Wires.

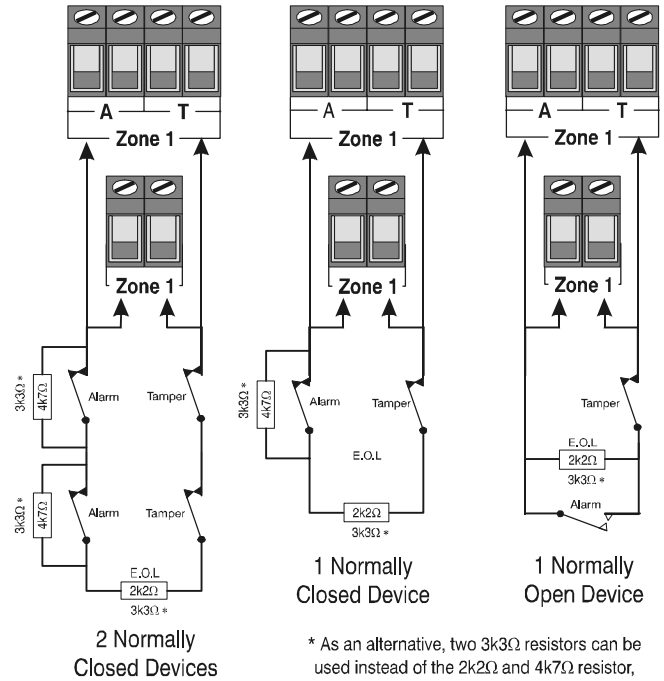

When Configuration Option 21 (see page 41 for details) is programmed as 'Short = Tamper' the system will respond as follows:

Zone Status	System Response
0 - 2k	Zone Tamper
2k1 - 4k6 (EOL)	Zone Secure
4k7 - 20k	Zone Active
21k+	Zone Tamper

NOTE When using this configuration, no more than 3 detectors can be connected to each zone.

When Configuration Option 21 (see page 41 for details) is programmed as 'Short = Active' the system will respond as follows:

Zone Status	System Response
0 - 2k	Zone Active
2k1 - 4k6 (EOL)	Zone Secure
4k7 - 30k	Zone Active
31k+	Zone Tamper

NOTE When using this configuration, no more than 5 detectors can be connected to each zone.

NOTE For details on testing zones, see page 73.

Auxiliary Tamper Connections

The Auxiliary Tamper terminals allow the control panel to monitor the tamper loops of external devices such as power supplies etc.

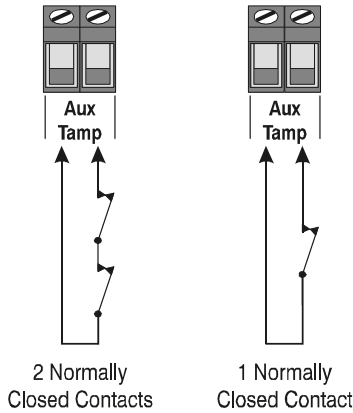

NOTE If the 'Auxiliary Tamper' terminals are not being used they must be linked out.

Speaker Connections

This output can be used for driving up to one 16Ω or two 8Ω loudspeakers as shown below:

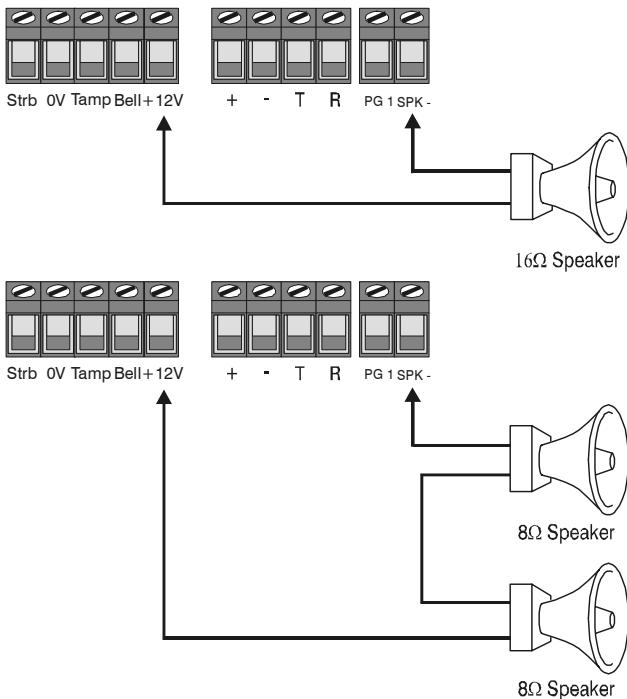

NOTE For details on testing Speaker outputs, see page 73

External Sounder Connections

The following terminals have been provided for connection to an external sounder:

(A) +12V
12V supply (protected by a 900mA PTC – F2). Normally connected to '+12V' on the sounder.

(B) Bell –
Sounder output, switches to 0V in alarm (SAB) and is rated at 500mA. Normally connected to Trigger -ve on the sounder. This output can also be programmed for SCB operation (see page 40 for details).

(C) Tamp
Negative tamper return. Normally connected to 'Tamper Out' on the sounder. If this terminal is not being used, it must be connected to '0V'.

(D) 0V
0V supply. Normally connected to '0V' on the sounder.

(S) Strb –
Strobe output, switches to 0V in alarm and is rated at 500mA. Normally connected to strobe -ve on the sounder (where applicable, connect the strobe +ve to +12V).

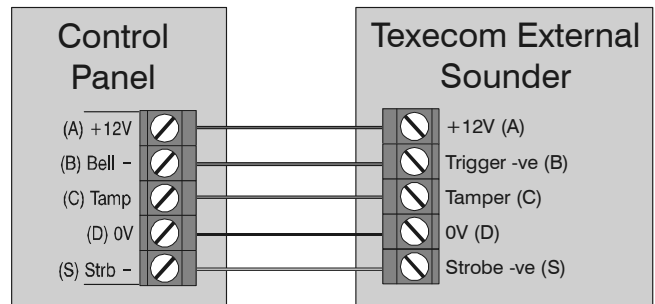

NOTE For details on testing the 'Bell' outputs, see page 73

When an Engineers code is entered to gain access to the programming menu, the Strobe output will pulse 3 times, invoking Engineers Hold Off mode if a Texecom bell box is connected.

Panel Outputs 1 - 6 and PG1

The control panel has 8 programmable outputs, which can be used to drive auxiliary devices such as LED's, sounders or relays etc. (see page 50 for programming details). The table below shows the electrical characteristics for each output:

Terminal	Max Current	Operation
1	100mA	Switched 0V
2	100mA	Switched 0V
3	100mA	Switched 0V
4	100mA	Switched 0V
5	100mA	Switched 0V
6	100mA	Switched 0V
PG1	100mA	Switched 0V
L/M	N/A	0V removed = Line Fault
R/R	N/A	0V applied to reset
DC+	N/A	+12V Power (unfused)
DC-	N/A	0V Power

Wiring Outputs

The diagram below shows some typical wiring examples:

-ve Applied Outputs

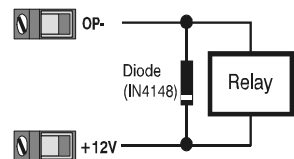
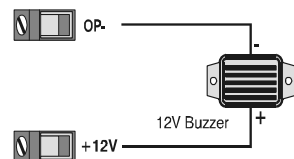
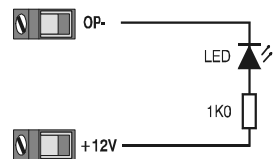

+ve Applied Outputs

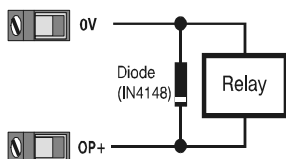
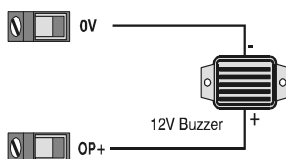
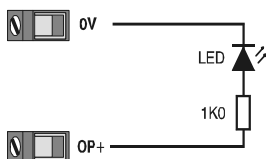

NOTE For details on testing outputs, see page 73.

Wiring a Stand Alone Communicator

The diagram below shows a typical wiring example:

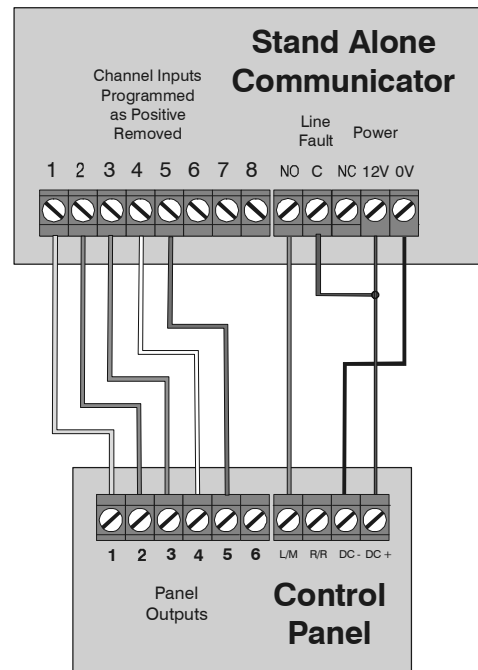

NOTE For details on testing the outputs, see page 73.

Plug-on Digimodems

The *Com300* is a multi format 8-channel digital communicator/300-baud modem for use with a standard analogue telephone line.

The *Com2400* is a multi format 8-channel digital communicator/2400-baud modem for use with a standard analogue telephone line in addition, this modem can also send Short Message Service (SMS) text messages to a mobile phone.

The *ComISDN* is a multi format 8-channel digital communicator/modem for use with an ISDN telephone line.

These Digimodem can be used to report system events to an Alarm Receiving Centre using Fast Format, Contact ID or SIA Level II or to upload/download control panel information using the *Wintex UDL* software and a PC.

Plugging on the Digimodem

Ensure that the board is the correct way up (see below). Locate the eight-pin plug into the digimodem socket on the control panel and line up the mounting holes with the pillars in the base. Once all the holes line up, press down gently until the pillars snap into the holes.

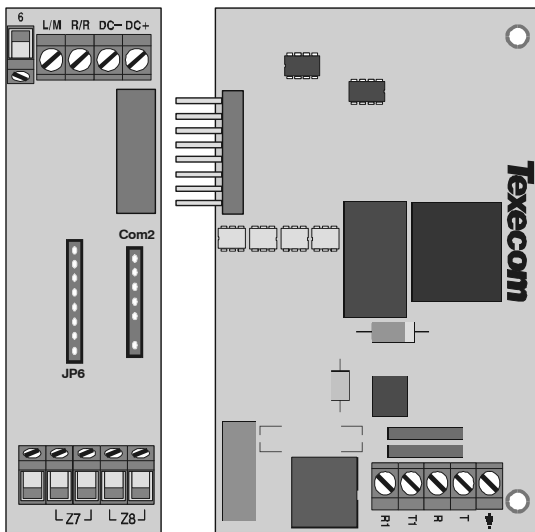

Standard Telephone Line Connections

A standard telephone line must be connected to the *Com300* or *Com2400* digimodem as shown below:

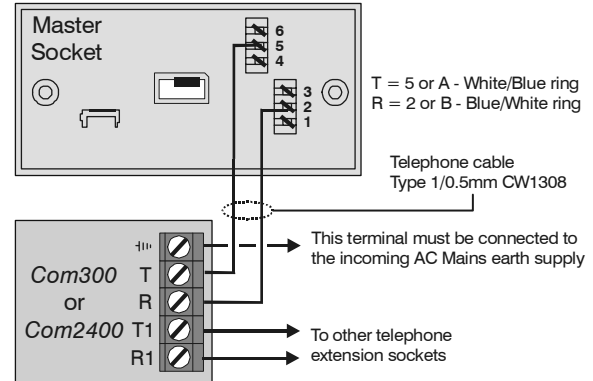

ISDN Telephone Line Connections

An ISDN telephone line must be connected to the *ComISDN* digimodem as shown below:

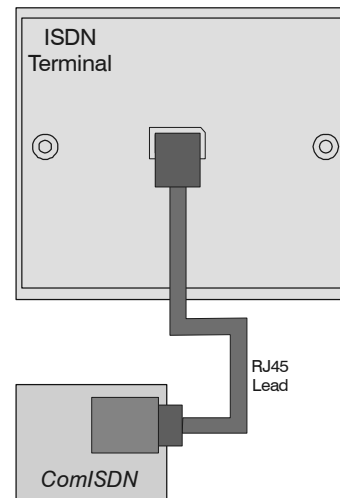

For details on testing the digimodems, see page 54.

RP9 Radio-Pad

Before connecting the *Radio-Pad*, isolate ALL power from the control panel (AC mains and battery), do not continue if there is still power present on the control panel.

To install the *Radio-Pad* onto the control panel:

- Connect the 7-Way connector of the *RPD-Com* lead to Com2 on the control panel
- Connect the 25-Way D-Type connector of the *RPD-Com* to the Radio-Pad
- Locate the power lead connector into the socket at the bottom of the Radio-Pad
- Connect the Black lead to the DC- terminal on the control panel
- Connect the lead with the White stripe to the DC+ terminal on the control panel
- Follow the procedure for **Registering the Radio-Pad**

Registering the Radio-Pad

Whenever a Paknet Radio-Pad is installed or moved, it must be **registered** onto the network. To do this:

- Press and hold the test button on the front of the Paknet Radio-Pad
- With the test button still pressed, connect power to the control panel and wait for the yellow service light on the Radio-Pad to flash
- Release the test button

Within 2 minutes the yellow service light should stop flashing and remain steady. This means that the Paknet Radio-Pad has now selected and locked on to the Base Station with the strongest signal.

The Paknet Radio-Pad should be re-registered on every site visit, this is to ensure that any new Vodafone Packet Radio Service Base Stations in the vicinity are recorded by the Paknet Radio-Pad.

Programming the Radio-Pad

- Program Com 2 for *Radio-Pad* operation (see page 61 for details)
- Refer to the *Radio-Pad* installation guide for full programming details.

GSM Module

Before connecting the *GSM Module*, isolate ALL power from the control panel (AC mains and battery), do not continue if there is still power present on the control panel.

To install the *GSM Module* onto the control panel:

- Connect the 7-Way connector of the *GSM-Com* lead to Com2 on the control panel
- Connect the RJ45 connector of the *GSM-Com* to the GSM Module
- Locate the power Jack Plug into the socket at the bottom of the *GSM Module*
- Insert a SIM card into the bottom of the *GSM Module*
- Connect power to the control panel

Programming the GSM Module

- Program Com 2 for *GSM Module* operation (see page 61 for details)
- Refer to the *GSM Module* installation guide for full programming details.

PC-Com

The *PC-Com* has two connectors. The 9-way D-type connector is for connection to a serial port on a computer and the 5-way Molex connector plugs onto Com 1 on the control panel.

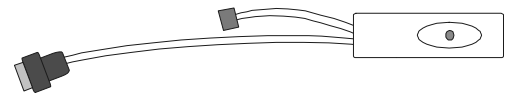

UNI-Com

The *UNI-Com* has two connectors. The 9-way D-type connector connects to any supported serial device, the 5-way Molex connector plugs onto Com 1 on the control panel.

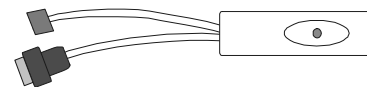

PRINT-Com

The *PRINT-Com* has two connectors. The 25-way D-type connector connects to a Serial Printer and the 5-way Molex connector plugs onto Com 1 on the control panel.

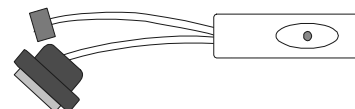

GSM-Com

The *GSM-Com* has four connectors. The RJ45 connector connects to the GSM Module, the 7-way Molex connector plugs onto Com 2 on the control panel, the 5-way Molex connector plugs onto the Audio connector on a Com300 or Com2400 and the jack plug connects to the power connector on the GSM Module to provide power (5V).

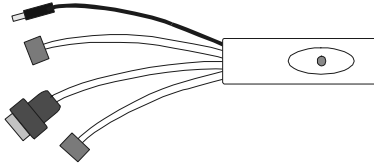

NET-Com

The *NET-Com* has two connectors. The RJ45 connector connects to a TCP/IP network and the 5-way Molex connector plugs onto Com 1 on the control panel.

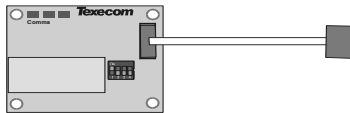

Connecting a Computer

The *Premier 24* supports local uploading and downloading between the control panel and a PC running *Wintex UDL* software. Uploading and Downloading can be used to program and interrogate the control panel.

In order for the computer to work correctly, ensure that it is set to the following:

- UDL Password (see page 60 for details)

NOTE In order to upload and download to the control panel locally, a *PC-Com* lead is required.

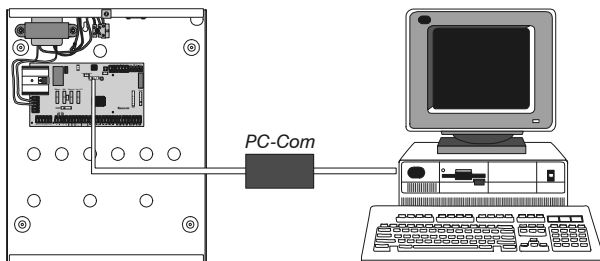

Connecting a Printer

The *Premier 24* supports printer facilities. The printer is connected to the Com 1 connector located on the control panel and can be used to print the control panel event log.

In order for the printer to work correctly, ensure that it is set to the following:

- Baud Rate = 4800
- Parity = None
- Start Bits = 1
- Stop Bits = 2
- Data Bits = 8
- DTR = Normal
- Columns = 40 or 80 (see page 40)

NOTE In order to connect a printer to the control panel, a *PRINT-Com* lead is also required.

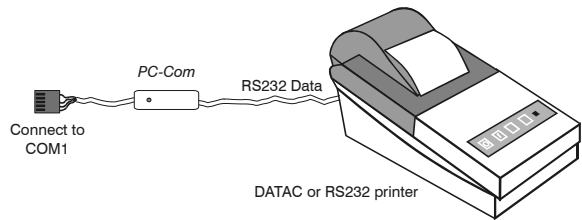

3. Commissioning and Troubleshooting

Commissioning

Once ALL connections have been made to the control panel and power is ready to be applied, you should read this section before continuing.

When applying power for the first time, the factory default settings must be loaded. The default settings ensure that the control panel software is reset and all programming information is loaded into memory. For a complete list of factory default settings, see page 26

The factory default settings are loaded by applying power to the control panel whilst at the same time, holding down the **Factory Default** button.

To default the control panel, proceed as follows:

- Connect the black battery lead to the negative (-) terminal of the standby battery and the red battery lead to the positive (+) terminal of the standby battery
- Press and hold the **Factory Default** button
- Press the battery kick-start button to connect the battery and ensure that the green power light illuminates
- After the power light has illuminated, let go of the **Factory Default** button (the power light will continue to flash whilst the factory default settings are being loaded, this can take up to 30 seconds)
- If the system goes into alarm, **enter the default Engineer code** (1) (2_{abc}) (3_{def}) (4_{ghi}), and the alarm tone will stop
- To access the Engineer Programming Menu, **enter the default Engineer code** (1) (2_{abc}) (3_{def}) (4_{ghi})
- Program the system as described in section 6 (Programming the Control Panel)
- Perform a zone test as described on page 73. Remember that some powered detectors (e.g. PIR's and combined technology detectors) take several minutes to warm up and become operational
- Test the internal sounder, external sounder and strobe as described on page 73
- Replace the lid and secure with the lid screw supplied
- **Press** (0_l) **followed by YES** to leave the programming menu, the system will return to normal
- The display will be showing that there is a 'Mains Power Off' condition. Switch on the AC mains supply to the control panel
- The normal banner message (if programmed) will now be displayed

Installation is now complete and the system is ready for use.

Trouble-Shooting

Control Panel

No Power to unit (mains only)

- Check the mains block fuse and replace if blown
- Check for loose wires at the mains block, the transformer and the AC terminals on the PCB
- Check the mains block is connected correctly; live to live (brown), neutral to neutral (blue)

No Power to unit (battery only)

- Don't forget to press the battery kick-start button
- Check the battery PTC LED for faults
- Check for loose wires at the BATT terminals on the PCB
- Check that the battery wires are connected correctly; red from BATT+ to the battery positive (+), black from BATT- to the battery negative (-)

Network Data LED's are not flashing

- Remove ALL power (AC Mains and Battery) and remove ALL wires from the network terminals. Then re-apply power again before referring to the Network Diagnostics table on page 10

External Sounder not Functioning (No 12V Output)

- Ensure that JP9 is fitted, as without this jumper link there will be no 12V power from the 12V Bell Terminals.

Keypads

Keypad does not operate

- Check that the keypad is wired correctly from the control panel (see page 10 for wiring details)
- Check the network PTC LED for faults
- Use the network diagnostics (see page 10 for details)

Keypad does not accept codes

- If the system has more than one keypad check that each keypad is addressed differently, see page 12 for details
- If the keypad is on a long cable run, check the voltage between the '+' and '-' terminals at the keypad and ensure that it measures no less than 10.0V
- Check that you are using the correct User codes. The default Engineer code is (1) (2_{abc}) (3_{def}) (4_{ghi}) and the default Master User code is (5_{jkl}) (6_{mno}) (7_{pqrs}) (8_{tuv})
- Check that the User code you are using is not 'Locked', if the User code is locked then the access code will only be accepted when the PGM is off (see page 42 for details)

Keypad zones do not operate

- Each keypad zone has to be mapped onto the system before it can be used (see page 46 for details)
- The zone is not programmed (see page 31 for details)

Keypad emergency keys do not operate

- Each keypad can be configured so that the emergency keys **PA**, **FIRE** and **MEDICAL** can be enabled or disabled. Check that the keypad has been programmed correctly (see page 46 for details)

Expander**Expander does not operate at all**

- Check that the expander is wired correctly from the control panel (see page 10 for wiring details)
- Check the network PTC LED for faults

System does not recognise zones

- If the expander is on a long cable run, check the voltage between the + and – terminals at the expander and ensure that it measures no less than 10.0V

The speaker output does not work

- The expander can be configured so that Alarm, Entry, Exit, Chime tones etc. can be enabled or disabled. Check that the expander has been programmed correctly (see page 48 for details)
- The speaker volume on the expander is electronically adjustable. Check the volume is set to the desired level (see page 48 for details)

Zones**One or more zones show an alarm**

- Check that the zone is wired correctly (see page 17 for wiring details)

Digimodem**The Digimodem will not dial**

- By default the communicator is disabled, check that the communicator is enabled (see page 58 for details)
- Check that the telephone line has been correctly wired to the communicator (see page 20 for wiring details)
- Check that the telephone numbers are programmed correctly (see page 57 for details)
- Check that the account numbers are programmed correctly (see page 57 for details)
- Check that the dial attempts are not programmed as zero (see page 57 for details)
- Check that the reporting options have been programmed correctly (see page 57 for details)

Digimodem dials but does not communicate

- Check that the telephone numbers are programmed correctly (see page 57 for details)
- Check that the correct protocol is programmed (see page 57 for details)

Operation**The system will not allow me to arm**

- Check that there are no outstanding problems (see page 25 for details)
- Check that there are no outstanding alarms that require resetting (see page 25 for details)
- Check that the User code has been programmed to allow arming (see page 69 for details)

The system will not allow me to disarm

- Check that the User code has been programmed to allow disarming (see page 69 for details)

Reset and Service Messages

When the system requires attention because of a potential problem, the display will show one of three service messages. These messages can also be accessed at any time, allowing the user to view installer information.



These messages would normally be programmed with the telephone numbers of the installer or the Alarm Receiving Centre (see page 43 for details).

To display the service messages, proceed as follows:

The display will normally show the time and date:

Tue 06 Mar 2001

Press **(Menu)** followed by **(1)** for the **Service** message:

Call Alarm Co.
For Service

Press **(Menu)** followed by **(2_{sec})** for the **Reset** message:

Call Engineer to
Reset System

Press **(Menu)** followed by **(3_{sec})** for the **Anti-code** message:

Call ARC to
Reset System

Press **(Reset)** to exit from the message, the display will then return to normal.

When alarm information is being displayed, pressing the SCROLL key will slow down the display and also allow manual scrolling through the events.

Fault Warning Tones

When a fault condition occurs i.e. mains fail, line fault etc. the internal sounders will chime every 30 seconds for 3 minutes. The chiming will automatically stop when a valid User code is entered, when **(Reset)** is pressed or after 3 minutes (whichever occurs first). The fault indication will only be cleared from the display when the fault has been rectified i.e. power, telephone line has been restored.

Other Messages

Alarm Engineer
Working On Site

The alarm engineer has logged into the programming menu and is working on site (this message will clear when the engineer logs off or the system is armed).

Confirm Devices
Tue 06 Mar 2001

The number of devices connected to the networks has changed from the last time a 'Confirm Devices' was done.

Remote Keypad is
now LOCKED out

To many invalid code attempts have caused the keypad to lock out. The keypad will remain like this for 5 minutes.

You need a user
to enable access

Engineer access has been programmed for Engineer code + User code (see page 40 for details).

Fault Messages

Service Required
Tue 06 Mar 2001

The service timer has expired indicating that the system requires a service, zones that have been placed on test have failed the test or a fault has occurred that requires attention (the system can normally still be used). Contact your alarm company to advise.

Mains Power Off
Tue 06 Mar 2001

There is a Mains failure (the keypad may chime every minute, enter a valid code to stop the chime). The display will automatically clear when mains is reapplied.

Phone Line Fault
Tue 06 Mar 2001

There is a Phone Line fault (the keypad may chime every minute, enter a valid code to stop the chime). The display will automatically clear when line fault clears.

* NO BATTERY *
Tue 06 Mar 2001

The Standby Battery has not been connected, the display will automatically clear after 1 minute.

Battery Fault
Tue 06 Mar 2001

There is a fault with the control panel standby battery.

Panel Lid Tamper
Tue 06 Mar 2001

There is a fault with the control panel lid tamper.

Bell Tamper
Tue 06 Mar 2001

There is a fault with the bell tamper on the control panel.

Auxiliary Tamper
Tue 06 Mar 2001

There is a fault with the auxiliary tamper on the control panel.

Bell Fuse Blown
Tue 06 Mar 2001

The bell/Strobe PTC has failed

Aux. Fuse Blown
Tue 06 Mar 2001

The 12V Auxiliary PTC has failed

RKP X Tamper
Tue 06 Mar 2001

There is a fault with the lid tamper of Keypad X.

RKP X Lost
Tue 06 Mar 2001

Keypad X has been lost off of the system.

EXP X Tamper
Tue 06 Mar 2001

There is a fault with the lid tamper of Expander X

EXP X Lost
Tue 06 Mar 2001

Expander X has been lost off of the system.

EXP X Lo Volts
Tue 06 Mar 2001

The voltage at expander X is very low.

EXP Bell Tamp X
Tue 06 Mar 2001

The expander's Bell input (that is programmed as bell tamper) is in fault.

EXP Aux Tamp X
Tue 06 Mar 2001

The expander's Auxiliary input (that is programmed as aux tamper) is in fault.

4. Factory Defaults

Menu	Option	Default
User Codes		
Setup Users	User 00 (Engineer)	1234
	User 01 (Master)	5678
	User 02 - 25	Not Defined
1. Zone Setup		
Zones Types	1	Entry/Exit 1
	2	Guard Access
	3 - 8	Guard
	All Other Zones	Not Used
Zone Text	All Zones	Not Defined
Zone Chime	All Zones	Silent
2. Arming Options		
Timers	Exit Delay	030 Seconds
	Entry Delay 1	015 Seconds
	Entry Delay 2	030 Seconds
	2 nd Entry Dly	000 Seconds
	Bell Delay	000 Minutes
	Bell Duration	015 Minutes
	Coms Delay	000 Seconds
	Part Bell Dly	000 Seconds
Arming Modes	Full Arm	Entry/Exit
	Part Arm 1	Instant
	Part Arm 2	Instant
	Part Arm 3	Instant
Options	1: Auto Part Arm	Disabled
	2: Part Arm Silent	Disabled
	3: Remote Arm/Disarm	Enabled
	4: Time Arm CT1	Disabled
	5: Alarm Eng Reset	Disabled
	6: Confirmation Reset	Enabled
	7: Tamper Eng Reset	Enabled
	8: Anti-code Reset	Enabled
	9: Arm With L/Fault	Enabled
	10: Arm With AC Fail	Enabled
	11: Part Arm Coms	Disabled
	12: Unarm Fire Coms	Disabled
	13: Unarm Tamper Coms	Disabled
	14: Log Part Omits	Disabled
	15: Confirm In Entry	Disabled
	16: Conf. After Entry	Disabled

Menu	Option	Default
3. Global Options		
System Timers	1: Exit Settle Time	008 Seconds
	2: Double Knock Dly	030 Seconds
	4: Activity Delay	024 Hours
	5: Abort Delay	180 Seconds
	6: Courtesy Time	060 Seconds
	7: Pulse Period 1	010 Seconds
	8: Line Fault Delay	030 Minutes
	9: AC Off Delay	030 Minutes
	10: Batt Test Period	024 Hours
	11: Batt Test Time	060 Seconds
	12: Soak Test Time	014 Days
	13: Service Interval	000 Weeks
	14: Test Call Every	000 Hours
	15: Zone Response	075x10mSec.
	16: Confirmation Dly	045 Minutes
	System Config.	00: Bell on Arm Fail
01: Bell is an SCB		SAB
02: Manual BST/GMT		Auto
03: Leave Omits		Remove
04: Enforce Com Delay		Override
05: NVM is Locked		Unlocked
06: Eng. + User Code		Engineer Only
07: Omit Tamper YES		NO
08: 40 Column Printer		80
09: View Act. Fault		Hide
10: View Zone Faults		Hide
11: Code Tamper		Enable
12: Code Tamp Locks		Alarms
13: Zone Short Active		Tamper
14: R/R=Silence/RST		Reset Only
15: Test Call = CT3		Timed
16: Batt Test = Disarm		Timed
17: Bell = 2nd Alarm		1st Alarm
18: SNDR = 2nd Alarm		1st Alarm
19: Abort = User Reset		Eng.
20: 8XE = Tamper 1-8		Zones 9-16
21: 1st Zone = Confirm		2nd Zone
22: Access = Confirm		No Conf.
23: EN50131 Enabled	Disabled	
System Options	1: Advisor Volume	5
	2: Chime Volume	3
	3: No. of Re-Arms	3
	4: Anti-code Resets	3
Control Timers	1 - 4	Not Defined
System Text	Reset Message	Call Engineer to Reset System
	Anti-code Message	Call ARC Centre to Reset System
	Service Message	Call Alarm Co. For Service
	Location Text	No Location Text Has Been Setup
	Banner Message	Not Defined
	Part Armed Banner	* PART ARMED *
	Printer Header	Printer Header
	Part Arm 1	Evening Arm
Part Arm 2	Bedtime Arm 1	
Part Arm 3	Bedtime Arm 2	
Speaker Tones	All Tones	Enabled

Menu	Option	Default
4. Keypad Setup		
Zone Mapping	All Keypad zones	Not Mapped
Options	1: PA Enabled 2: Fire Enable 3: Medical Enabled 4: Tamper Disabled 5: PA Audible 6: PA Delayed 7: Quick Arm Keys 8: Info.LED> Output	Disabled Disabled Disabled Enabled Silent Instant Off Armed
Volume	All Keypads	5
Sounder Options	All Tones	Enabled
5. Expander Setup		
Text	All Expanders	Not Defined
Auxiliary Input	All Expanders	Not Used
Volume	All Expanders	5
Sounder Options	All Tones	Enabled
6. Output Setup		
Panel Outputs	1 2 3 4 5 6 7 (Strobe Output) 8 (Bell Output)	Fire PA Alarm Armed Confirmed Abort Strobe Bell
Com? Channels	1 2 3 4 5 6 7 8	Fire PA Alarm Armed Zones Locked Out Not Used Confirmed Abort
PGM Outputs	1 2 3 4 5-8	Zones Locked Out Not Used Full Arm Entry Control Timer 4 Not Used
Keypad Outputs	1 - 8	Not Used
Expander Outputs	1 - 8	Not Used

Menu	Option	Default
7. UDL/Digi Options		
Reset Digi	N/A	N/A
Test Com?	N/A	N/A
Program Digi	ARC Set 1 ARC Set 2	Not Defined Not Defined
Digi Options	Digi is Enabled Pulse Dialling Pulse After 3 Blind Dialling Call Waiting On Dial All Numbers	Disabled Tone Always Tone Wait Dial Tone Off Dial Any
UDL Options	Call Back Number 1 Call Back Number 2 UDL Password DL Attended Manual Call-Back Call Defeat on ARM DL Limited Only Full Armed DL Keypad Active Rings Required UDL Dial Attempts	Not Defined Not Defined Not Defined Disabled Enabled Enabled Disabled Disabled Disabled 005 003
Radio/SMS Opt.	Pad ARC1 Pri. No. Pad ARC1 Sec. No.	Not Defined Not Defined
Radio/SMS Opt.	Pad ARC2 Pri. No. Pad ARC2 Sec. No. Pad ARC2 Prefix SMS Centre Pri. SMS Centre Sec.	Not Defined Not Defined Not Defined Not Defined 07860980480 Not Defined
Com Port Setup	Onboard Digi Com 1 Com 2	Com300 No Module Fitted No Module Fitted
8. User Codes		
Setup Users	User 00 (Engineer) User 01 (Master) User 02 - 16	1234 5678 Not Defined

5. The Programming Menu

Introduction

All engineers should read this section carefully so as to familiarise themselves with the programming of the control panel.

To access the Programming menu, **enter the factory default Engineer code** (1) (2_{abc}) (3_{def}) (4_{ghi}).

If a mistake is made whilst entering the Engineer code, simply re-enter the correct code.

WARNING

When an Engineers code is entered to gain access to the Programming menu, by default ALL zones and tampers are disabled.

The Strobe output will also pulse 3 times, invoking Engineers Hold Off mode if a Texecom bell box is connected.

A menu option can then be selected by pressing one of the keys shown or by using the (↕) key to search. Once selected, **press YES** to access that option.

To leave the selected menu option and return to the main programming menu, **press** (Reset).

To exit from the Main Programming menu but still remain 'Logged' onto the system (zones and tampers still disabled), **press** (Reset) and the display will show 'Alarm Engineer Working On Site'.

To log the Engineer off the system, **press** (0) followed by **YES** and the system will revert to its normal condition.

The table below shows the menu options available:

Key	Menu Option	Page
(1)	Zone Setup	31
(2 _{abc})	Arming Options	35
(3 _{def})	Global Options	39
(4 _{ghi})	Keypad Setup	45
(5 _{jkl})	Expander Setup	47
(6 _{mno})	System Outputs	48
(7 _{pqrs})	UDL/Digi Options	54
(8 _{tuv})	Setup Users	66
(9 _{wxyz})	Engineer Utils	71
(Part)	Alter Part Arms	76
(Menu)	The Arming Menu	-
(0)	Log Off Engineer	30
(Reset)	Exit programming mode	30

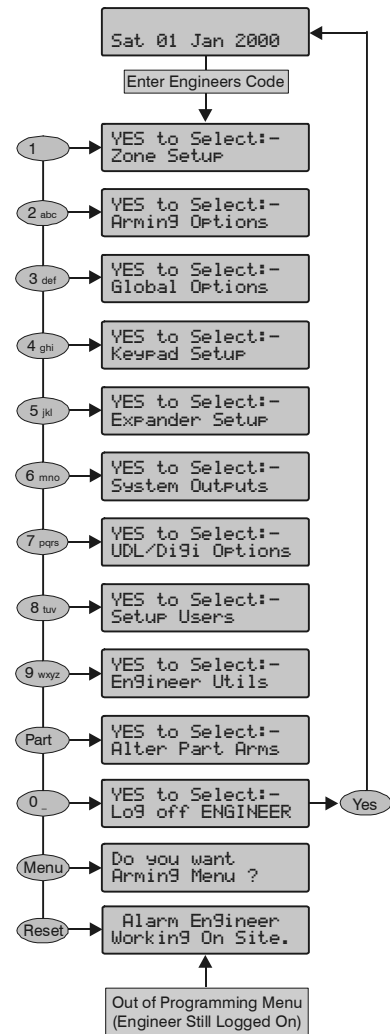

Programming Menu Guide

Key	Main Menu	Key	Sub Menu
1	Zone Setup	Yes Yes Yes Yes Yes	Zone Types Zone Attributes 1 Zone Attributes 2 Zone Text Zone Wiring
2 _{abc}	Arming Options	0 _{...} 1 5 _{kl}	Timers Arming Modes Options
3 _{def}	Global Options	0 _{...} 1 2 _{abc} 4 _{ghi} 5 _{kl} 8 _{tuv}	System Timers System Config. System Options Control Timers System Text Speaker Tones
4 _{ghi}	Keypad Setup	Yes Yes Yes Yes	Zone Mapping Options Speaker Volume Sounder Options
5 _{kl}	Expander Setup	Yes Yes Yes	Auxiliary Input Speaker Volume Sounder Options
6 _{mno}	System Outputs	0 _{...} 1 2 _{abc} 4 _{ghi} 5 _{kl}	Panel Outputs Com? Channels PGM Outputs Keypad Outputs Expander Outputs
7 _{pqrs}	UDL/Digi Options	0 _{...} 1 3 _{def} 4 _{ghi} 5 _{kl} 7 _{pqrs} 8 _{tuv}	Reset Digi Test Com? Program Digi Digi Options UDL Options Radio/SMS Options Com Port Setup
8 _{tuv}	Setup Users	Yes Yes Yes Yes Yes	User Code User Type User Options User Text Program TAG
9 _{wxyz}	Engineer Utils	0 _{...} 1 2 _{abc} 3 _{def} 4 _{ghi} 5 _{kl} 6 _{mno} 7 _{pqrs} 8 _{tuv} 9 _{wxyz} ↕	View Event Log Do Bell Test Do Walk Test View Zone Status System Tests Confirm Devices View RKP Status View Exp. Status Set System Time Set System Date Change Eng. Code

Key	Main Menu	Key	Sub Menu
Part	Part Arms	Omit Chime Part	Part Arm 1 Part Arm 2 Part Arm 3
Menu	Arming Menu	0 _{...} 1 2 _{abc} Omit Chime 5 _{kl}	Exit Menu Arm System Part Arm System Omit Zones Set Chime Use Anti-code
Menu	User Menu	0 _{...} 1 2 _{abc} Chime 4 _{ghi} 5 _{kl} 6 _{mno} 7 _{pqrs} 8 _{tuv} 9 _{wxyz} Part ↕ ↕	Exit Menu View Event Log Change Code Edit Chime Zones Bell Tests Walk Test Enable Engineer Set System Time Set System Date Setup Users Alter Part Arms Call Remote PC Edit Phone No's
Reset	Exit programming menu (engineer still logged on)		
0 _{...}	Log Off Engineer		













6. Programming the Control Panel

Introduction

Programming Text

Text is programmed in a similar way to mobile phones. Characters are selected by pressing the corresponding key the appropriate number of times (to select a character on the same key, press  to move the cursor along).

The table below shows the keys to use and the characters that are assigned to them:

Key	Character											
	_	0										
	.	,	?	!	1	@	"	-	&	%	/	+ = \$: ;
	A	B	C	2	a	b	c					
	D	E	F	3	d	e	f					
	G	H	I	4	g	h	i					
	J	K	L	5	j	k	l					
	M	N	O	6	m	n	o					
	P	Q	R	S	7	p	q	r	s			
	T	U	V	8	t	u	v					
	W	X	Y	Z	9	w	x	y	z			
	Move Cursor											
	Backspace (delete)											





Log Off Engineer

Whenever the Engineer Programming menu is exited by pressing  twice, the display will look like this:





This message will stay on the display until the Engineer logs off.

► To log off, proceed as follows:

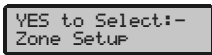
Enter an Engineer code    , the display should look like this:



Press  or , the display should look like this:

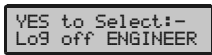



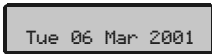

Press  to return to normal, the display will look something like this:



The Engineer is now logged out of the Programming menu.

Reset the Engineers Code (User 00)

If the Engineer code (User 00) has been lost or forgotten, it can normally be reset back to the factory default of    . However, this can only be done if the NVM has not been locked (see page 40 for details).

To Reset the Engineer code (User 00):

ENSURE THAT THE LID TAMPER IS OPEN

Short out the 'Load Default' pins for 5 seconds (with the control panel still powered), after 5 seconds, the sounders/keypads will bleep to indicate that the Engineer code has been reset.

 **NOTE** NO other codes/programming will be affected, it is just the User 00 Engineer code that will be reset.

The Engineer (User 00) code can only be reset, if the NVM has not been locked (see page 40 for details).

6.1 Zone Setup

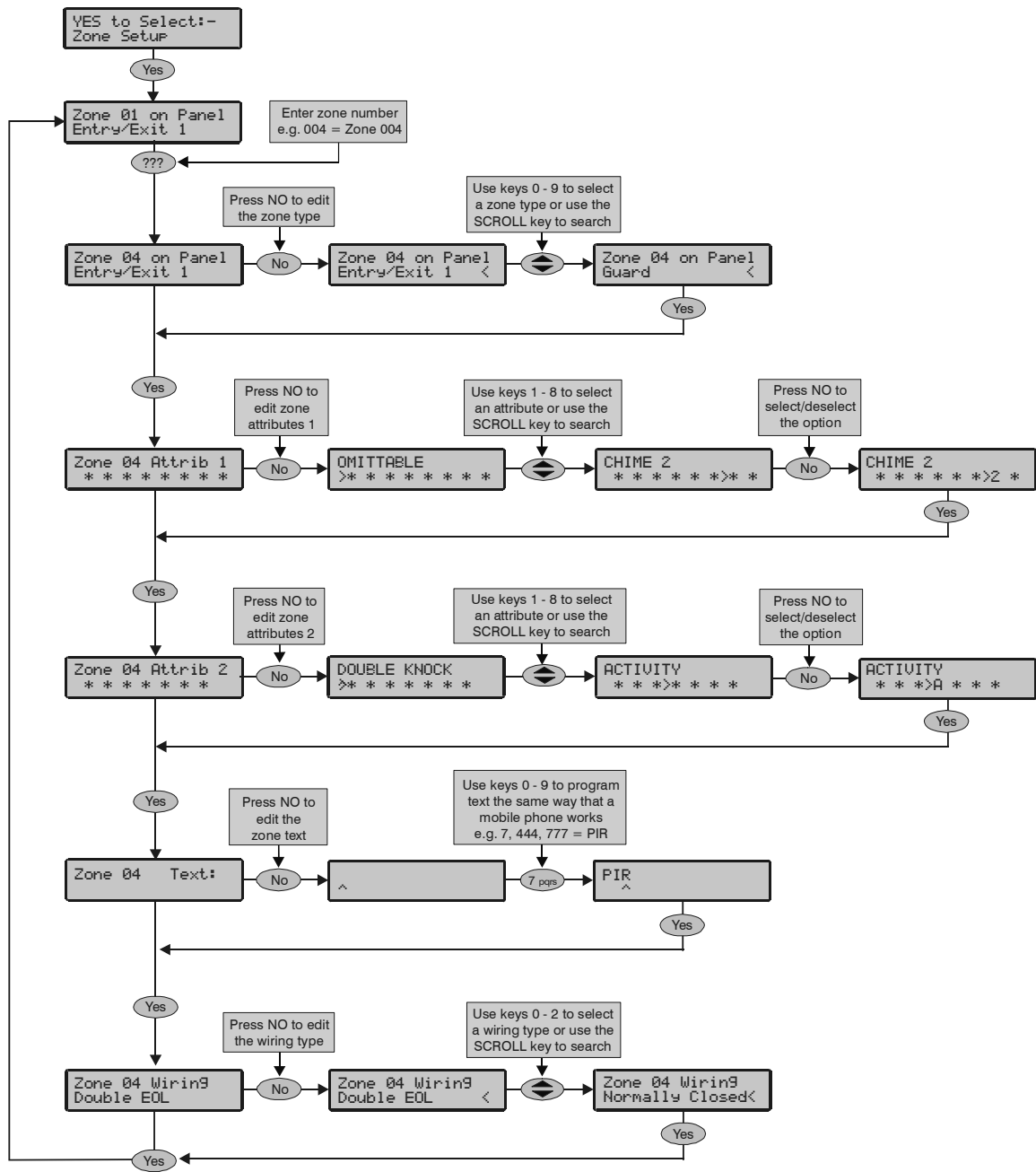

Zone Types

Each zone must be programmed before it is recognised by the system.

Zone numbers are entered as a two digit number i.e. Zone 1 would be entered as 01. Each zone consists of a zone type, attributes, zone text and wiring type.

When programming zones, first select a zone type then select any required attributes, program any required zone text and then select the wiring type.

Zone Type + Zone Attributes 1 + Zone Attributes 2 + Zone Text + Wiring Type = Zone Programmed.

The following zone types are available:

0 - Not used

A zone that is not monitored by the system, unused zones should be programmed as 'Not Used' or linked out.

1 - Entry/Exit 1

Normally used for the main entry/exit door i.e. Front Door. The zone can be activated during the exit mode without causing a 'Fault'. Once the system is armed, activation of the zone will start the 'Entry 1 Delay' timer.



NOTE

If an Entry/Exit 1 or 2 zone type is omitted, 'Guard Access' zones will automatically become 'Entry/Exit 1' zones to allow access into the premises without causing an alarm.

2 - Entry/Exit 2

Normally used for another entry/exit door that requires a different entry delay i.e. Back Door, Garage Door etc. The zone can be activated during the exit mode without causing a 'Fault'. Once the system is armed, activation of the zone will start the 'Entry 2 Delay' timer.

3 - Guard

Normally used for detection devices such as PIR's, Door Contacts etc. This zone type will cause an Intruder alarm if it is activated when the system is armed. This zone type will also activate any output programmed as 'Guard Alarm'.

4 - Guard Access

Normally used for detection devices along the entry/exit route. This zone type will allow the user to walk past the detector without causing a 'Fault' during the exit mode or an Intruder alarm during the entry mode, however, the zone will cause an immediate Intruder alarm if activated at any other time. This zone type will also start the entry mode when the system is part armed and activate any output programmed as 'Guard Access Alarm'.

5 - 24Hr Audible

This zone type will cause an internal alarm if it is activated when the system is disarmed and will cause an Intruder alarm when the system is armed. The panel will also report a '24-Hour' alarm to the Alarm Receiving Centre when using 'Contact ID' reporting.

6 - Trouble

When the system is disarmed, a Trouble zone will show on the display when activated and the display will clear when the zone returns to healthy without the need for a code to be entered. However, when the zone is active it will prevent the alarm from being armed. When the system is armed, the zone will not cause any type of alarm.

7 - PA Audible

Normally used for monitoring Panic or hold-up alarms. This zone type will cause a Panic alarm if it is activated when the system is armed or disarmed.

8 - PA Silent

Normally used for monitoring Panic or hold-up alarms. This zone type will cause a silent Panic alarm if it is activated when the system is armed or disarmed.

9 - Fire

Normally used for monitoring smoke detectors. This zone type will cause a Fire alarm with distinctive fire tone if it is activated when the system is armed or disarmed. In addition, the bell output will pulse.

10 - 24Hr Gas

This zone type will cause an Audible alarm if it is activated when the system is armed or disarmed. The panel will also report a 24-Hour Gas alarm to the Alarm Receiving Centre when using 'Contact ID' reporting.

10 - Auxiliary

This zone type will cause a Silent alarm if it is activated when the system is armed or disarmed. The panel will also report an Auxiliary alarm to the Alarm Receiving Centre when using 'Contact ID' reporting.

11 - Tamper

This zone type will cause an Internal alarm if it is activated when the system is disarmed and will cause an Intruder alarm when the system is armed.

13 - Exit Terminator

This zone type is used to finalise the arming procedure when arming the system (see page 36 for details).

14 - Key Switch

This zone type can be used to arm and disarm the alarm system. When the zone is activated and then secured the system will arm. When the zone is subsequently activated and then secured the system will disarm. Tamper faults will not arm or disarm anything, but will cause a Tamper alarm.

Zone Attributes 1

Attributes can be assigned to a zone to alter its operation i.e. a Guard zone with the 'Access' attribute will allow the user to walk past the detector without causing a 'Fault' during the exit mode or an Intruder alarm during the entry mode.

Select attributes by pressing keys 1 to 8 (a letter on the display means the attribute is selected, a star on the display means the attribute is not selected).

The following attributes are available:

O - Omittable

Zones with this attribute can be manually omitted.

Zones without this attribute cannot be manually omitted.

F - Force Omit

Zones with this attribute will be omitted if they are not secure at the end of the exit mode.

Zones without this attribute will cause an 'Arm Fail' if they are not secure at the end of the exit mode.

1 - Part 1 Omit

Zones with this attribute will be omitted when 'Part Arm 1' is selected. Keyswitch zones with this attribute will perform a 'Part Arm 1'.

Zones without this attribute will not be omitted when 'Part Arm 1' is selected.

2 - Part 2 Omit

Zones with this attribute will be omitted when 'Part Arm 2' is selected. Keyswitch zones with this attribute will perform a 'Part Arm 2'.

Zones without this attribute will not be omitted when 'Part Arm 2' is selected.

3 - Part 3 Omit

Zones with this attribute will be omitted when 'Part Arm 3' is selected. Keyswitch zones with this attribute will perform a 'Part Arm 3'.

Zones without this attribute will not be omitted when 'Part Arm 3' is selected.

1 - Chime 1

Zones with this attribute will cause the internal sounders to generate a single Chime tone when activated.

2 - Chime 2

Zones with this attribute will cause the internal sounders to generate a double Chime tone when activated.

G - Guard

Zones with this attribute will cause an Intruder alarm when the system is part armed (this would normally be used on 'Entry/Exit 1 or 2' zone types).

Zones without this attribute will respond as normal.

Zone Attributes 2

Select attributes by pressing keys 1 to 8 (a letter on the display means the attribute is selected, a star on the display means the attribute is not selected).

The following attributes are available:

D - Double Knock

Zones with this attribute will only cause an alarm if it is activated twice within the 'Double Knock' time window or for the duration of the time window.

Zones without this attribute will respond as normal.

S - Shunt Group

Zones with this attribute will be isolated whenever a 'Shunt' code is entered or a 'Shunt' keyswitch is operated and will be reinstated when the code or keyswitch is used again.

Zones without this attribute will respond as normal.

T - On Soak Test

Zones with this attribute will not cause an alarm if activated during the 'Soak Test Time' (see page 39 for details). However, the system will record the event in the log and indicate to the user that the zone has failed the test. A test failure will NOT prevent the user from arming and will clear when an Engineer code is entered.

Zones without this attribute will respond as normal.

A - Activity

Zones with this attribute will cause an activity fault to be displayed at the time of arming if they have not been activated during the 'Activity Delay' period. If 'Config. option 14' (see page 40 for details) has been set to 'Activity Fault Bar' the system cannot be armed until the zone has been activated (forced walk test).

Zones without this attribute will respond as normal.

R - Reset

Zones with this attribute will not be monitored during the 'Detector Reset' period i.e. when the exit mode is started and power is removed from certain detectors (to reset them) the 'Fault' on the zone is ignored.

Zones without this attribute will be monitored as normal.

I - Inverted

Zones with this attribute will report their 'Secure' and 'Active' status the opposite way round. 'Tampers' always respond as normal.

Zones without this attribute will respond as normal.

Q - Quick Resp.

The response time of zones with this attribute is governed by the 'Zone Loop' response Timer (see page 39 for details).

The response time of the zone is fixed at 250mS.

! - Shock

Zones with this attribute will cause any 'Entry/Exit 1' zone type to automatically become a 'Guard' zone for 10 seconds.

Zones without this attribute will respond as normal.

Attributes for Moment or Latch Keys

Select attributes by pressing keys 1 to 8 (a letter on the display means the attribute is selected, a star on the display means the attribute is not selected).

The following attributes are available for Keyswitch zones:

I - Instant Arm

The system will arm instantly instead of using the exit timer.

S - Shunt Key

When the zone is 'Active', any zone with the 'Shunt' attribute will be isolated until the zone returns to 'Secure'.

F - Full Disable

When using a key switch to 'Full' arm the system, the key switch is disabled once it is armed.

P - Disarm Only

The keyswitch can only be used to disarm the system.

F - Silent Arming

When using a keyswitch to arm, the system will arm silently.

I - Inverted

The operation of the keyswitch is inverted.

Q - Quick Resp.

The response time of the zones with this attribute is governed by the 'Zone Loop' response Timer

L - Latching

When the keyswitch is 'Active', the system will arm. When the zone is 'Secure', the system will disarm.

Zone Text

Each zone can have up to 16 characters of descriptive text assigned to it. Text is programmed in a similar way to mobile phones. Select characters by pressing the corresponding key the appropriate number of times (to select a character on the same key, press  to move the cursor along).

The table below shows the keys to use and the characters that are assigned to them:

Key	Character															
0	_	0														
1	.	,	?	!	1	@	"	-	&	%	/	+	=	\$:	;
2	A	B	C	2	a	b	c									
3	D	E	F	3	d	e	f									
4	G	H	I	4	g	h	i									
5	J	K	L	5	j	k	l									
6	M	N	O	6	m	n	o									
7	P	Q	R	7	p	q	r	s								
8	T	U	V	8	t	u	v									
9	W	X	Y	9	w	x	y	z								
	Move Cursor															
Reset	Backspace (delete)															

Zone Wiring Type

The following wiring configurations are available for each zone on the system. For wiring details please see page 17.

- 0 - Normally Closed (Single Pole)
- 1 - Normally Open (Single Pole)
- 2 - Double EOL

 **NOTE** When wiring double pole (4-wires) to a keypad or zone expander, the wiring configuration must always be programmed as 'Double EOL'.

DD 243:2002

To comply with DD 243:2002, during the normal entry delay, the control panel must prevent a Confirmed Intruder Alarm from being reported to the Alarm Receiving Centre.

If a Portable ACE i.e. Electronic Keyswitch, Key Fob, Tag, Swipe Card etc. is being used for disarming, it is permissible for the Confirmed Intruder Alarm signal to be re-enabled after the entry delay has expired.

WARNING

Owing to the ability to disable ALL of the confirmation facilities, the customer should be advised in writing by the alarm company that ALL means of alarm confirmation are disabled when the initial entry door is opened. The alarm company should then obtain written acceptance from the customer of the disabling of the means of alarm confirmation.

6.2 Arming Options

Timers

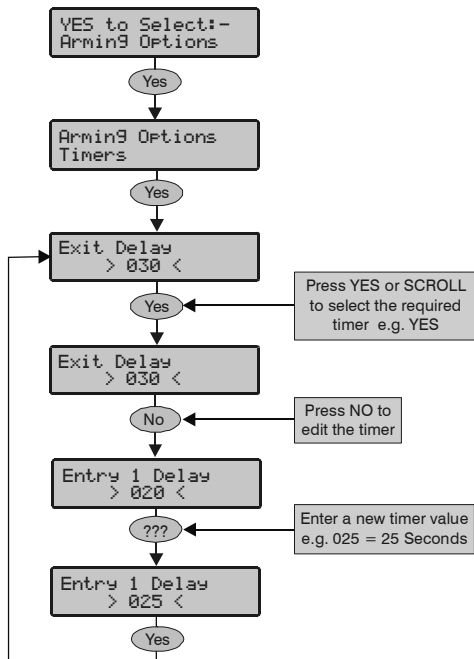

There are 8 timers that control timing and delay functions. Each timer can be programmed for any value between 000 and 255.

1 - Exit Delay

When the exit mode is programmed as 'Timed' this timer controls the delay between the user initiating the exit mode for the system actually arming (Default = 030 Seconds).

2 - Entry 1 Delay

If the system is armed and an 'Entry/Exit 1' zone is activated, this timer will start and the entry tone will be heard. If the system is not disarmed before this timer expires, the '2nd Entry Delay' timer will start. (Default = 015 Seconds).

3 - Entry 2 Delay

If the system is armed and an 'Entry/Exit 2' zone is activated, this timer will start and the entry tone will be heard. If the system is not disarmed before this timer expires, the '2nd Entry Delay' timer will start. (Default = 030 Seconds).

4 - 2nd Entry Dly

When the 'Entry Delay 1 or 2' timer expires, this timer will start and an Internal alarm will occur. If the system is still not disarmed before this timer expires, an Intruder alarm will then occur (Default = 000 Seconds).

5 - Bell Delay

This timer controls the delay between an Intruder alarm occurring and the 'Bell/Strobe' output activating (Default = 000 Minutes).

6 - Bell Duration

This timer controls the duration of the 'Bell' output after an Intruder alarm has occurred and any programmed 'Bell Delay' has expired (Default = 015 Minutes).

7 - Coms Delay

This timer controls the delay between an Intruder alarm occurring and the communicator reporting to the Alarm Receiving Centre (Default = 000 Seconds).

8 - Part Bell Dly.

When the system is 'Part Armed' this timer controls the delay between an Intruder alarm occurring and the 'Bell/Strobe' output activating, the internal sounders will also sound during this time as a warning (Default = 000 Minutes).

Arming Modes

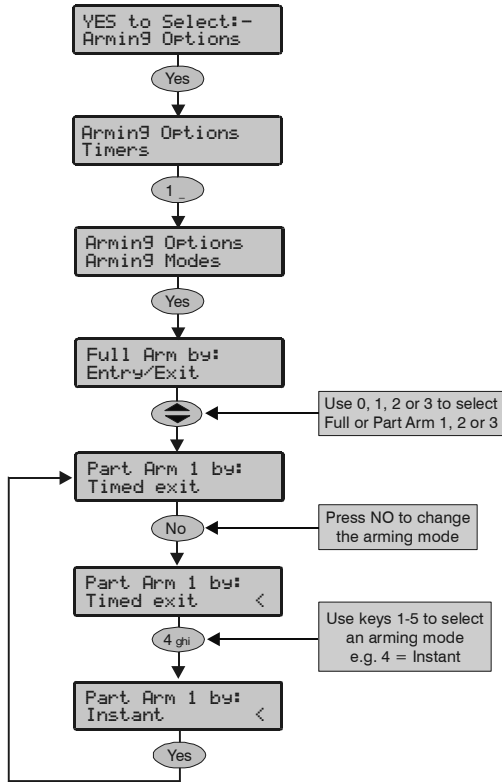

The way that an the system arms can be configured for any of the following options:

1 - Entry/Exit

The system will arm after the 'Entry/Exit' door has been closed and the 'Exit Settle' timer has expired.

2 - Exit Term.

The system will arm after the 'Entry/Exit' door has been closed, the 'Exit Terminator' button has been pressed and the 'Exit Settle' timer has expired.

3 - Timed Exit

The system will arm after the programmed 'Exit Time' has expired.



If an 'Exit Terminator' zone is activated at any point during the exit mode, any remaining exit time is cancelled and the system will arm immediately.

4 - Instant

The system will arm instantly.

5 - Deferred

The system will arm after the programmed 'Exit Time' has expired. However, if any zones not on the exit route are activated during the exit mode, the 'Exit Time' is restarted.

Options

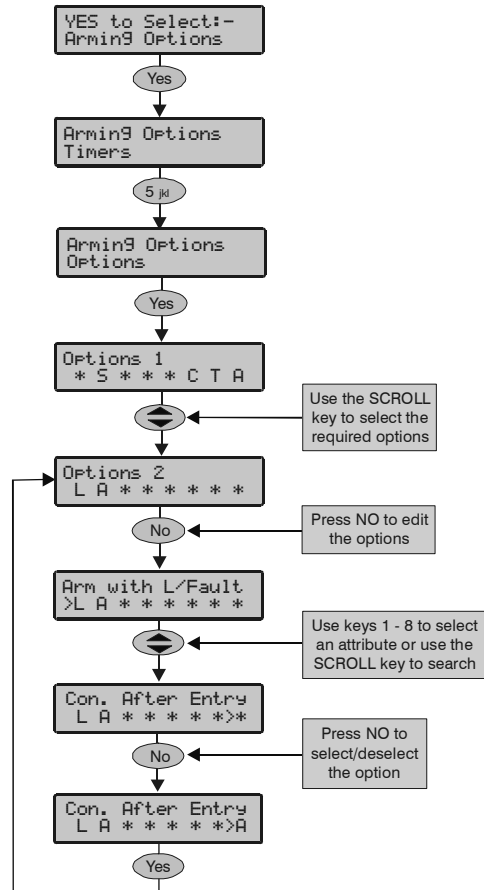

There are 16 options that control how various features affect the alarm.

Options 1

A - Auto Part Arm (Default = Disabled)

The system will fully arm if an 'Entry/Exit' zone is activated during the exit mode and will 'Part Arm 1' if an 'Entry/Exit' zone is not activated during the exit mode.

S - Part Arm Silent (Default = Disabled)

The system will always Part Arm silently.

R - Remote Arm/Disarm (Default = Enabled)

The system can be armed and disarmed remotely using the *Wintex UDL* software and a PC or *GSM Module*.

T - Time Arm CT1 (Default = Disabled)

The system will automatically arm using Control timer 1.

E - Alarms Eng Reset (Default = Disabled)

The system can be programmed for Engineer or User reset following an Intruder alarm, if programmed as 'Alms Eng Reset' the system will respond as follows:

A normal Intruder alarm can only be reset using an Engineer code

If 'Anti-code Reset' is enabled (option 11) the system can also be reset using the Anti-code

C - Confirmed Reset (Default = Enabled)

The system can be programmed for Engineer or User reset following a Confirmed alarm, if programmed as 'Confirmed Reset' the system will respond as follows:

A confirmed Alarm can only be reset using an Engineer code

If 'Anti-code Reset' is enabled (option 11) the system can also be reset using the Anti-code

T - Tamper Eng Reset (Default = Enabled)

The system can be programmed for Engineer or User reset following a Tamper alarm (when the system is unarmed), if programmed as 'Tamper Eng Reset' the system will respond as follows:

A Tamper Alarm can only be reset using an Engineer code

If 'Anti-code Reset' is enabled (option 11) the assigned areas can also be reset using the Anti-code

A - Anti-code Reset (Default = Enabled)

The system can be programmed for Anti-code Reset following an Intruder or Tamper alarm, if programmed as 'Anticode Reset' the system will respond as follows:

An Alarm condition can be reset using the Anti-code as well as an Engineer code



The system can only be programmed for 'Anti-code Reset' if it is also programmed as 'Alarms Eng Reset'.

Options 2

L - Arm With L/Fault (Default = Enabled)

The system can be armed with a line fault present.

A - Arm with AC Fail (Default = Enabled)

The system can be armed with a mains fault present.

P - Part Arm Coms (Default = Disabled)

When 'Part Arm Coms' is enabled the system will respond as follows:

When the system is part armed and an Intruder alarm occurs, Intruder alarm events are reported to the Alarm Receiving Centre after any programmed 'Coms Delay' has expired

F - Unarm Fire Coms (Default = Disabled)

When 'Unarm Fire Coms' is enabled, Fire alarm events will be reported to the Alarm Receiving Centre whilst the system is disarmed



Fire alarm events are always reported to the Alarm Receiving Centre when the system is armed regardless of whether this option is enabled or not.

T - Unarm Tamp. Coms (Default = Disabled)

When 'Unarm Tamp Coms' is enabled, 24Hr and Tamper alarm events (for that area) will be reported to the Alarm Receiving Centre whilst the system is disarmed



24Hr and Tamper alarm events are always reported to the Alarm Receiving Centre when the system is armed regardless of whether this option is enabled or not.

L - Log Part Omits (Default = Disabled)

When enabled, zones that have been omitted during a part arm are logged in the event log.

I Confirm in Entry (Default = Disabled)

When 'Confirm in Entry' is enabled the system will respond as follows:

Once the entry timer is started if two or more zones are activated a Confirmed alarm will occur, and will be reported to the Alarm Receiving Centre



To comply with DD 243:2002, this option must NEVER be enabled, thus preventing Confirmed Alarms from being reported to the Alarm Receiving Centre during the entry mode.

A - Conf. after Entry (Default = Disabled)

When 'Conf. After Entry' is enabled the system will respond as follows:

Once the entry timer expires if two or more zones (not on the entry route) are activated a Confirmed alarm will occur, and will be reported to the Alarm Receiving Centre



If a Portable ACE i.e. Electronic Keyswitch, Key fob, Tag, Swipe Card etc. is used to disarm the system, it is permissible for the Confirmed Intruder Alarm signal to be re-enabled after the entry delay has expired. In this case, this option CAN be enabled.

DD 243:2002 Options

To comply with DD 243:2002, during the normal entry delay, the control panel must prevent a Confirmed Intruder Alarm from being reported to the Alarm Receiving Centre.

If a Portable ACE i.e. Electronic Keypad, Key Fob, Tag, Swipe Card etc is being used for disarming, it is permissible for the Confirmed Intruder Alarm signal to be re-enabled after the entry delay has expired.

The previous two options have been provided to ensure that the control panel can be programmed to comply with this standard if required.

WARNING

Owing to the ability to disable ALL of the confirmation facilities, the customer should be advised in writing by the alarm company that ALL means of alarm confirmation are disabled when the initial entry door is opened. The alarm company should then obtain written acceptance from the customer of the disabling of the means of alarm confirmation.

6.3 Global Options

System Timers

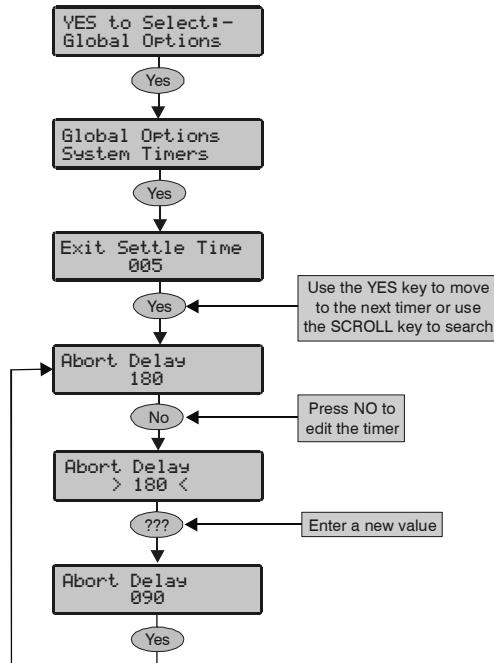

There are 15 global timers that control system timing and delay functions. Each timer can be programmed for any value between 000 and 999.

1 - Exit Settle Time

When using the 'Entry/Exit' or 'Exit Terminator' arming mode, some detectors along the exit route can remain active for a number of seconds following activation. This timer ensures that the detectors are given time to deactivate before the system arms. (Default = 008 Seconds).

2 - Double Knock Dly

If a zone has the 'Double Knock' attribute an alarm will only occur if the zone activates twice within this time window or once for the duration of this time window. (Default = 030 Seconds).

3 - Activity Delay

If a zone has the 'Activity' attribute and it is not activated during this timer and 'Config. option 14' has been set to 'View Act. Fault' (see page 40 for details), it will be indicated to the user when they try to arm the system. (Default = 024 Hours).

4 - Abort Delay

When an Intruder alarm occurs this timer is started, if the system is disarmed within this time window an 'Abort' event will be reported to the Alarm Receiving Centre. If the system is disarmed after this period the 'Abort' event is not reported. (Default = 180 Seconds).

5 - Courtesy Time

This timer controls the duration of the 'Courtesy' output type. The courtesy output activates whenever a keypad is being used and during the entry mode. (Default = 060 Seconds).

6 - Pulse Period 1

This timer controls how long any output with the 'Pulse Period 1' attribute assigned to it will activate for. (Default = 010 Seconds).

7 - Line Fault Delay

This timer controls the delay between a line fault occurring and an audible indication being generated by the system. (Default = 030 Minutes).

8 - AC Off Delay

This timer controls the delay between an AC Mains failure occurring and an audible indication being generated by the system. (Default = 030 Minutes).

9 - Batt Test Period

This timer controls the frequency of the dynamic battery test. (Default = 024 Hours).

10 - Batt Test Time

This timer controls how long the dynamic battery test is carried out for. (Default = 060 Seconds).

11 - Soak Test Time

This timer controls the number of days a zone with the 'Test' attribute will remain on test for. (Default = 014 Days).

12 - Service Interval

This timer controls the frequency of the 'Service Required' condition occurring. (Default = 000 Weeks).

13 - Test Call Every

This timer controls how often a test call is made to the monitoring station. 024 = daily etc. (Default = 000 Hours).

14 - Zone Response

This timer controls the length of time that a zone with the 'Quick Response' attribute, has to be activated for, in order to be recognised by the control panel. (Default = 075x10mSeconds).

15 - Confirmation Dly

When an Intruder alarm occurs, this timer starts. If a second (different) zone is activated within this time window, the 'Confirmed' output will activate. When this timer expires, the 'Confirmed' output will no longer activate. (Default = 045 Minutes).

System Config.

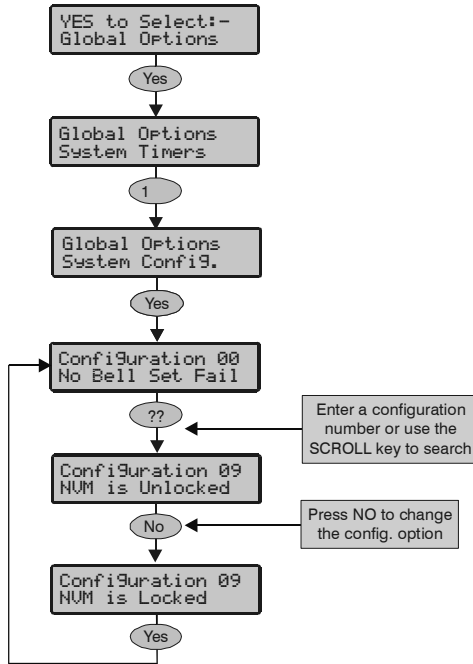

These options control how various system functions work.

00 - No Bell Arm Fail (Default)

If the system fails to arm, an Internal alarm will occur and the 'Strobe' output will activate.

Bell on Arm Fail

If the system fails to arm, an Internal alarm will occur and the 'Bell' output will activate for 10 seconds.

NOTE The 'Strobe' output will also activate for 5 seconds to indicate that the system has armed and disarmed successfully.

01 - Bell is an SAB (Default)

The 'Bell' output on the control panel applies 0V when it activates.

Bell is an SCB

The 'Bell' output on the control panel removes 0V when it activates.

02 - Manual BST/GMT

The system clock will not adjust itself at the beginning and the end of the summer (the clock will have to be adjusted manually).

Auto BST/GMT (Default)

The system clock will adjust itself at the beginning and the end of the summer (the clock will automatically gain 1Hr on the last Sunday in March and lose 1Hr on the last Sunday in October).

03 - Leave Omits

When zones have been 'Omitted' by a user, the zones will remain omitted until the user reinstates them.

Remove Omits (Default)

When zones have been 'Omitted' by a user, the zones will be automatically reinstated when the system is disarmed.

04 - Override Com Dly (Default)

If the system is 'Fully' armed and an Intruder alarm occurs, Intruder alarm events are reported to the Alarm Receiving Centre immediately.

Enforce Com Dly

If the system is 'Fully' armed and an Intruder alarm occurs, Intruder alarm events are reported to the Alarm Receiving Centre after any programmed 'Coms delay' has expired (see page 35 for details).

05 - NVM is Unlocked (Default)

The factory default settings can be reloaded by shorting the load default pins during power up.

NVM is Locked

The factory default settings cannot be reloaded by shorting the load default pins during power up.

NOTE If the NVM is locked and the Engineer User code has been lost or forgotten, the control panel will have to be returned to Texecom to be unlocked.

06 - Engineer Only (Default)

Access to the Engineers Programming menus can be obtained by just entering the Engineer User code.

User + Engineer

Access to the Engineers Programming mode can only be obtained, if a User (with the 'Engineer Access' attribute) has authorised engineer access.

07 - Omit Tamper No (Default)

A user cannot omit Tamper faults on a zone.

Omit Tamper Yes

A user can omit Tamper faults on a zone.

08 - 80 Column Print (Default)

Select this option when connecting a 80 Column printer to the control panel.

40 Column Print (Default)

Select this option when connecting a 40 Column printer to the control panel.

09 - Hide Act. Fault (Default)

If a zone with the 'Activity' attribute is not activated during the 'Activity Delay' time window, the system can still be armed. However, this fault will be indicated to the user when they try to arm.

View Act. Fault

If a zone with the 'Activity' attribute is not activated during the 'Activity Delay' time window, the system cannot be armed. This situation can only be overcome by activating the zone.

10 - View Zone Faults

Active zones and their status are always displayed in real time on the keypad when the system is disarmed.

Hide Zone Faults (Default)

Active zones and their status are never displayed in real time on the keypad when the system is disarmed.

11 - Enable Code Tamper (Default)

24 invalid key presses on a keypad will cause a Code Tamper condition (see option 17).

No Code Tamper

A Code Tamper condition will never occur when the keys on a keypad are pressed more than 24 times.

12 - Code Tamper Alarm (Default)

A Code Tamper condition will cause a Tamper alarm.

Code Tamper Lockout

A Code Tamper condition will cause the keypad to lockout for 5 minutes.

13 - Short = Active

The control panel will see a zone that is in the short circuit condition as 'Active'.

Short = Tamper (Default)

The control panel will see a zone that is in the short circuit condition as a 'Tamper'.

14 - R/R=Reset Only (Default)

When 0V is applied to the control panel R/R input, any outstanding alarms will be reset (see page 37 for details).

R/R=Silence/RST

When 0V is applied to the control panel R/R input the internal sounders will be silenced. When 0V is applied to the R/R input a second time, any outstanding alarms will be reset. (this would normally be used when Audio Verification is required).

15 - Timed Test Call (Default)

A test call to the Alarm Receiving Centre will occur every time the 'Test Call Every' timer expires.

Test Call = CT3

A test call to the Alarm Receiving Centre will occur every time 'Control Timer 3' activates.

16 - Batt Test Timed (Default)

A battery test will occur every time the 'Batt Test Period' timer expires.

Batt Test = Disarm

A battery test will occur every time the system is disarmed or after the 'Batt Test Period' timer has expired (whichever occurs first).

17 - Bell = 1st Alarm (Default)

The 'Bell' and 'Strobe' outputs will activate after an Intruder alarm (1st Alarm) occurs.

Bell = 2nd Alarm

The 'Bell' and 'Strobe' outputs will activate after a Confirmed alarm (2nd Alarm) occurs.

18 - SNDR = 1st Alarm (Default)

The internal sounders will sound after an Intruder alarm (1st Alarm) occurs.

SNDR = 2nd Alarm

The internal sounders will sound after a Confirmed alarm (2nd Alarm) occurs.

19 - Abort=Eng.Reset (Default)

An Intruder alarm that is aborted can only be reset by an Engineer/Anti-code.

Abort=User Reset

An Intruder alarm that is aborted can be reset by the User.

20 - 8XE = Zones 9-16 (Default)

The 8 zones on the 8XE local zone expander will report as zones 9 to 16.

8XE = Tamper 1-8

The 8 zones on the 8XE local zone expander will report as the tampers for zones 1 to 8.

21 - 2nd Zone = Confirm (Default)

After the entry timer has expired, activation of 2 more zones is required to generate a Confirmed alarm

1st Zone = Confirm

After the entry timer has expired, activation of 1 more zone is required to generate a Confirmed alarm

22 - Access No Conf. (Default)

Zones programmed as 'Guard Access' can never generate a confirmed alarm once the entry timer has started.

Access = Confirm

Zones programmed as 'Guard Access' can generate a confirmed alarm once the entry timer has expired.

23 - EN50131 Disabled (Default)

The Control Panels EN50131 options are disabled.

EN50131 Enabled

The Control Panels EN50131 options are enabled.



This options must be enabled to comply with EN50131

System Options

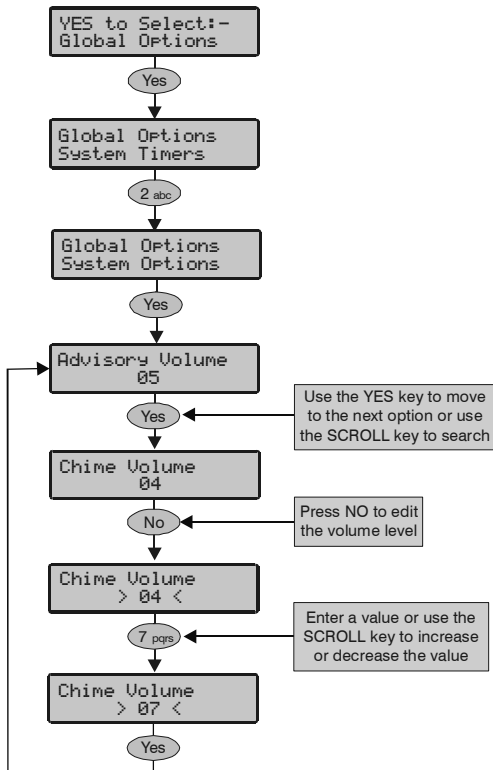

There are 4 options that control various system functions.

1 - Advisory Volume

This option controls the volume level of advisory tones from loudspeakers connected to the keypads. Advisory tones consist of 'Entry/Exit' and 'Warning' type tones. 1 = minimum; 8 = maximum. (Default = 5).

NOTE Alarm tones are always full volume and Chime tones are not affected by this value.

2 - Chime Volume

This option controls the volume level of Chime tones from loudspeakers connected to the control panel. 1 = minimum; 8 = maximum. (Default = 3).

NOTE Alarm and advisory tones, are not affected by this value.

3 - No. Of Re-Arms

This option controls the number of times that a zone will re-arm. Once the re-arm limit has been reached, the zone is 'Locked Out' and will not cause any further Intruder alarms. (Default = 3).

4 - Anti-code Resets

This option controls how many Anti-code or Remote Resets can be performed by the user. Once the 'No. of resets' limit has been reached, an Intruder alarm can only be reset using an Engineer code. This reset counter is cleared every month or whenever an Engineers code is entered. (Default = 3).

Monitor Hardware

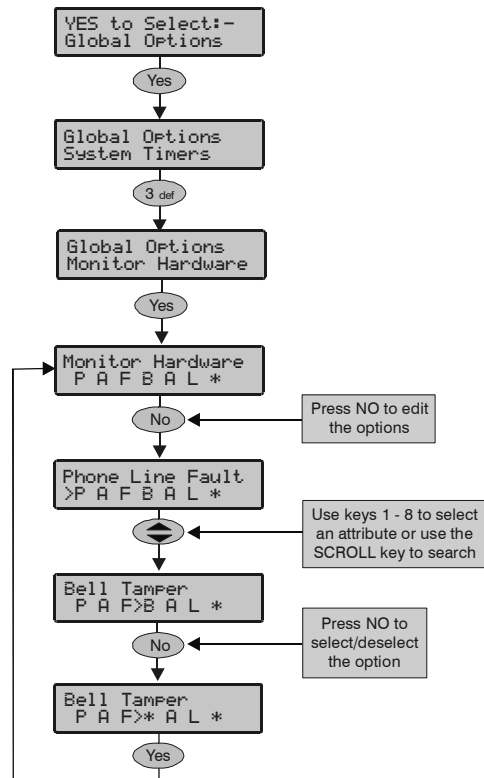

The control panel monitors many inputs for fault conditions i.e. the panel lid tamper, bell tamper, aux fuse etc.

Each one of these options can be disabled to overcome problems related to the devices being monitored.

P - Phone Line Fault (Default = ON)

The telephone line is monitored for faults.

A - AC Power Failure (Default = ON)

The AC Mains is monitored for faults.

F - Aux Fuse Blown (Default = ON)

The Auxiliary Fuse/PTC is monitored for faults.

B - Bell Tamper (Default = ON)

The external sounder tamper loop is monitored for faults.

A - Aux Tamper (Default = ON)

The auxiliary tamper loop is monitored for faults.

L - Panel Lid Tamper (Default = ON)

The control panel lid tamper is monitored for faults.

B - Battery Faults (Default = OFF)

The dynamic battery test is enabled.

Control Timers

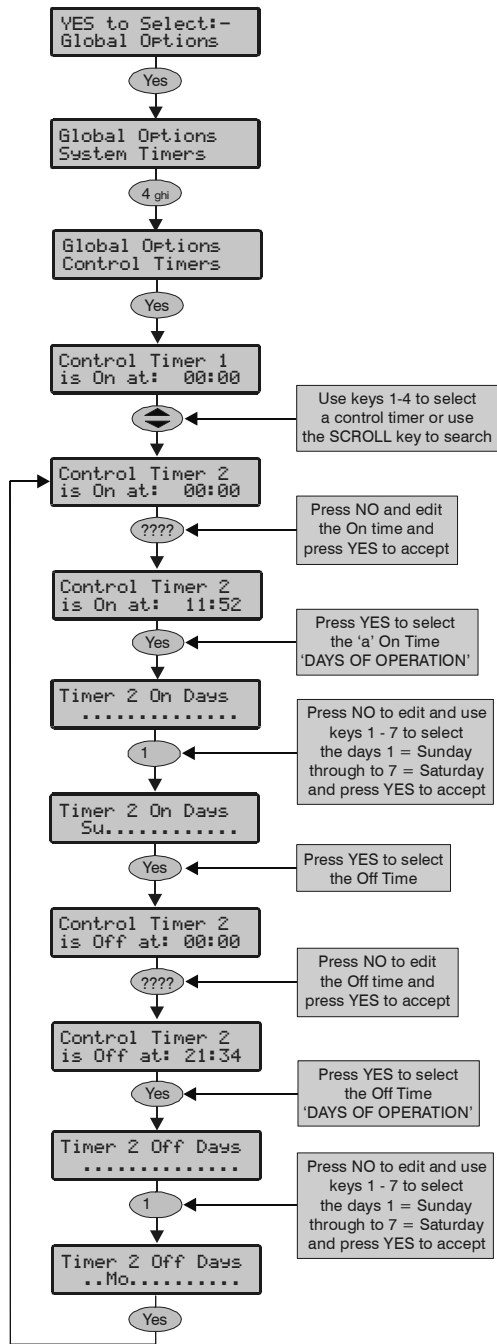

There are 4 control timers. Each timer has an ON and OFF time, and can be programmed to operate on any day of the week. Once configured, the timers can be used to arm or disarm the system, lockout users and control outputs.

System Text

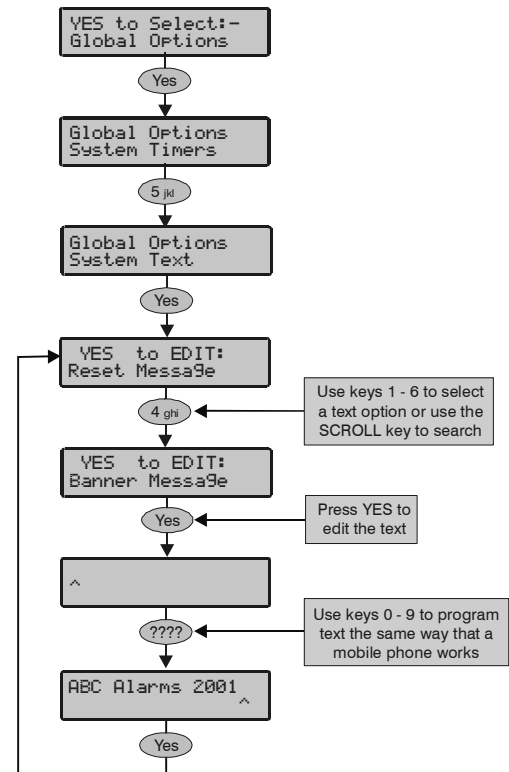

The system has 7 programmable text messages.

1 - Reset Message

This 32-character message is displayed whenever the control panel requires an Engineer reset.



Default = Call Engineer to Reset System.

2 - Anti-code Msg.

This 32-character message is displayed whenever the control panel requires an Anti-code Reset.



Default = Call ARC Centre to Reset System.

3 - Service Message

This 32-character message is displayed whenever the control panel requires Daytime reset.



Default = Call Alarm Co. for Service.

4 - Location Text

This 32-character message is displayed whenever the engineer views the location text in 'Engineer Utils'.



Default = No Location Text Has Been Setup.

5 - Banner Message

This 16-character message is displayed above the time and date whenever the control panel is unarmed or fully armed.

NOTE Default = ' (Not Defined).

6 - Part Arm Banner

This 16-character message is displayed above the time and date whenever the control panel is part armed.

NOTE Default = * PART ARMED *

7 - Printer Header

This 16-character header will be printed whenever a log printout is taken from the control panel or a Short Message Service (SMS) text message is sent to a mobile phone.

NOTE Default = 'Printer Header'

8 - Part Arm 1

This 16-character message is displayed above the time and date whenever the control panel is unarmed or fully armed.

NOTE Default = Evening Arm

9 - Part Arm 2

This 16-character message is displayed above the time and date whenever the control panel is unarmed or fully armed.

NOTE Default = Bedtime Arm 1

10 - Part Arm 3

This 16-character message is displayed above the time and date whenever the control panel is unarmed or fully armed.

NOTE Default = Bedtime Arm 2

Speaker Tones

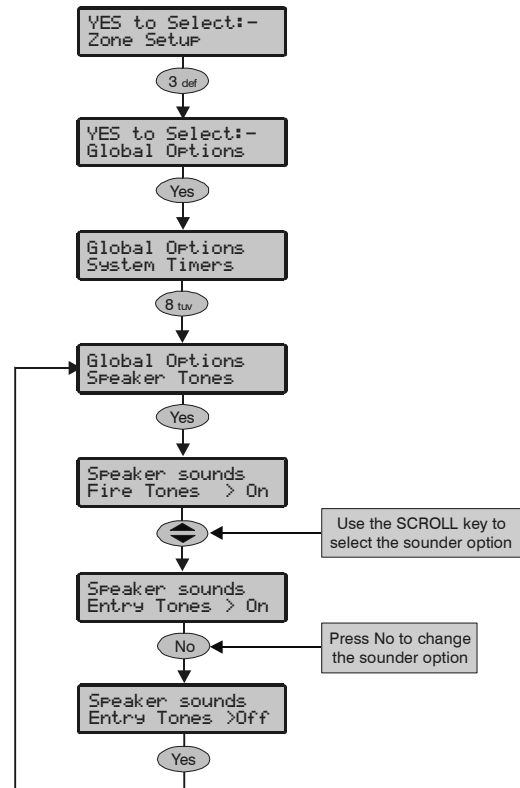

The speaker output on the control panel can be programmed so that certain types of tones are not generated. When deselected, Fire, Alarms, Fault, Service, Entry, Exit and Chime tones will not be heard.

Select tones by pressing keys 1 to 8 (a letter on the display means the tone is selected, a star on the display means the tone is not selected).

F - Fire Tones On (Default = ON)

Fire alarm tones will be generated.

A - Alarm Tones On (Default = ON)

Intruder alarm, Tamper alarm and PA alarm tones will be generated.

F - Fault Tones On (Default = ON)

Fault tones will be generated.

S - Service Tone On (Default = ON)

Service and Warning tones will be generated.

E - Entry Tones On (Default = ON)

Entry tones will be generated.

X - Exit Tones On (Default = ON)

Exit tones will be generated.

C - Chime Tones On (Default = ON)

Chime 1 and 2 tones will be generated.

6.4 Keypad Setup

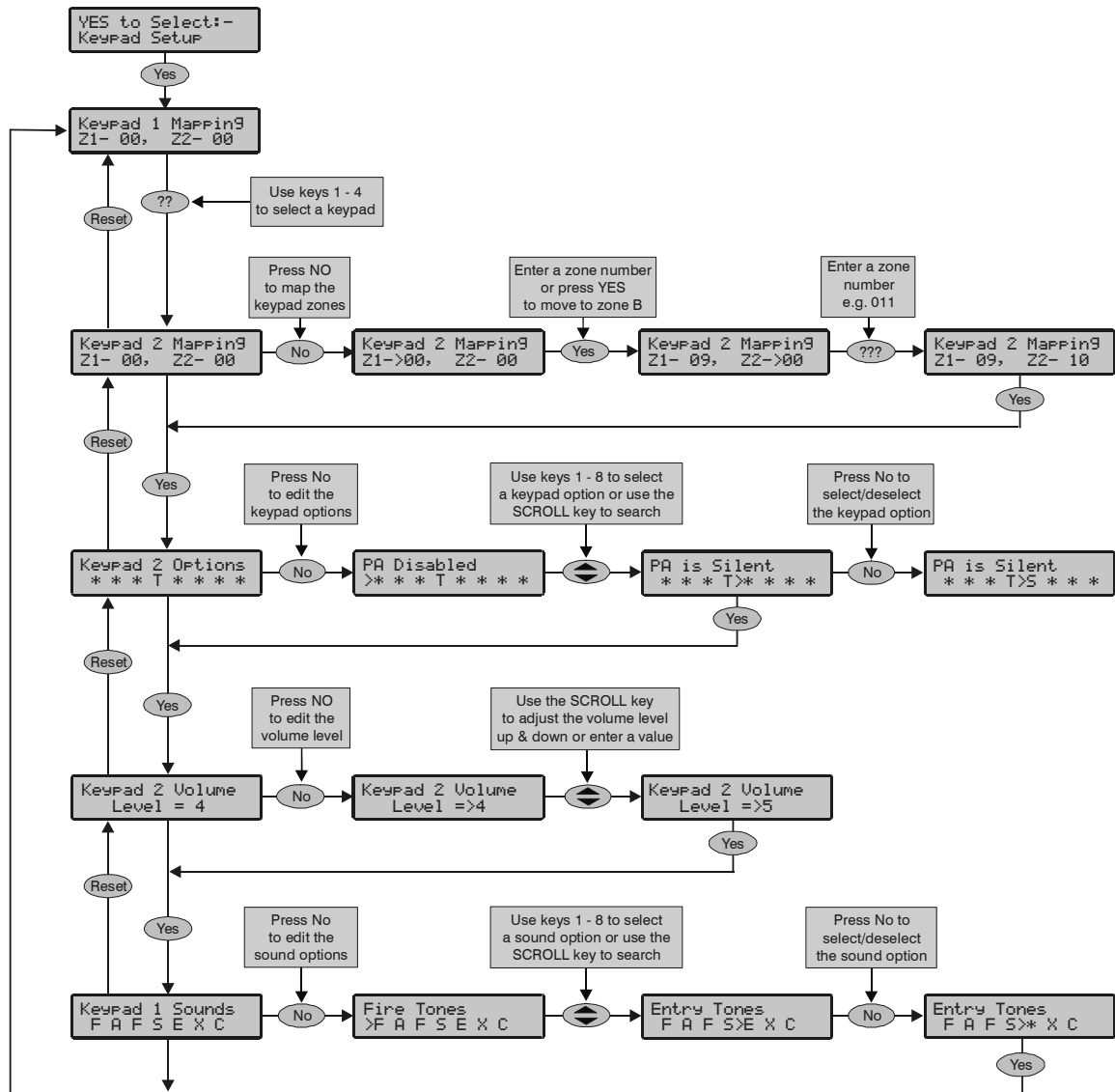

Keypad Zone Mapping

The zones in the keypad need to be mapped to a valid zone number before they can be used as part of the system i.e. Keypad 1 Zone 1 could be mapped to Zone 5 (panel) and Zone 2 could be mapped to Zone 23 (expander 2) etc.



Until they are mapped, the zones in the keypads will not work and will not be seen by the control panel.

A keypad zone can be mapped to any zone number on the system, however, when mapped to a zone number that already exists i.e. Zone 5 (panel), that zone can no longer be used.

If a zone is mapped to a zone number not already on the system i.e. Zone 23 (expander 2) and expander 2 is then added, that zone on the expander (Zone 23) cannot be used.

If you wish to use the zone on the expander, the keypad zone must be remapped to a different number.

If a zone is remapped to a different number, the new zone number must be treated as a new zone on the system and therefore needs to be programmed accordingly (the zone programming will NOT automatically follow the mapping).

The table below shows the zone allocation when the keypads are installed:

Address	Zones
1 to 8	Not Mapped

Keypad Options

These 8 options control various keypad functions:

P - PA Enabled

Pressing keys 1 & 3 together will cause a PA alarm.

F - Fire Enabled

Pressing keys 4 & 6 together will cause a Fire alarm.

M - Medical Enabled

Pressing keys 7 & 9 together will cause a Medical alarm.

T - Tamper Enabled (Default)

Removing the keypad cover will cause a Tamper alarm.

A - PA Audible

A keypad PA (1 & 3) will cause an audible PA alarm.

D - PA Delayed

When the keypad PA buttons (1 & 3) are pressed, a 30 second 'Keypad PA Delay' timer starts, if a User code is entered before the timer expires, no PA alarm will occur. If no User code is entered before the timer expires, a PA alarm will occur.

Q - Quick Arm is Enabled

Pressing the Area or Part keys will Arm or Part Arm the alarm without the need to enter a User code first.

O - Info.LED> Output

The 'Info.' LED on the keypad comes on when the keypad output activates and goes off when the keypad output deactivates.

Keypad Speaker Volume

This option controls the volume level of advisory tones from loudspeakers connected to the keypads. Advisory tones consist of 'Entry/Exit' and 'Warning' type tones. 1 = minimum; 8 = maximum. (Default = 5).



Alarm tones are always full volume.

Keypad Sounder Options

The sounder and speaker output in the keypad can be programmed so that certain types of tones are not generated. When deselected, Fire, Alarms, Fault, Service, Entry, Exit and Chime tones will not be heard.

Select tones by pressing keys 1 to 8 (a letter on the display means the tone is selected, a star on the display means the tone is not selected).

F - Fire Tones On (Default = ON)

Fire alarm tones will be generated by the keypad sounder/speaker.

A - Alarm Tones On (Default = ON)

Intruder alarm, Tamper alarm and PA alarm tones will be generated by the keypad sounder/speaker.

F - Fault Tones On (Default = ON)

Fault tones will be generated by the keypad sounder/speaker.

S - Service Tone On (Default = ON)

Service and Warning tones will be generated by the keypad sounder/speaker.

E - Entry Tones On (Default = ON)

Entry tones will be generated by the keypad sounder/speaker.

X - Exit Tones On (Default = ON)

Exit tones will be generated by the keypad sounder/speaker.

C - Chime Tones On (Default = ON)

Chime 1, 2 and 3 tones will be generated by the keypad sounder/speaker.

6.5 Expander Setup

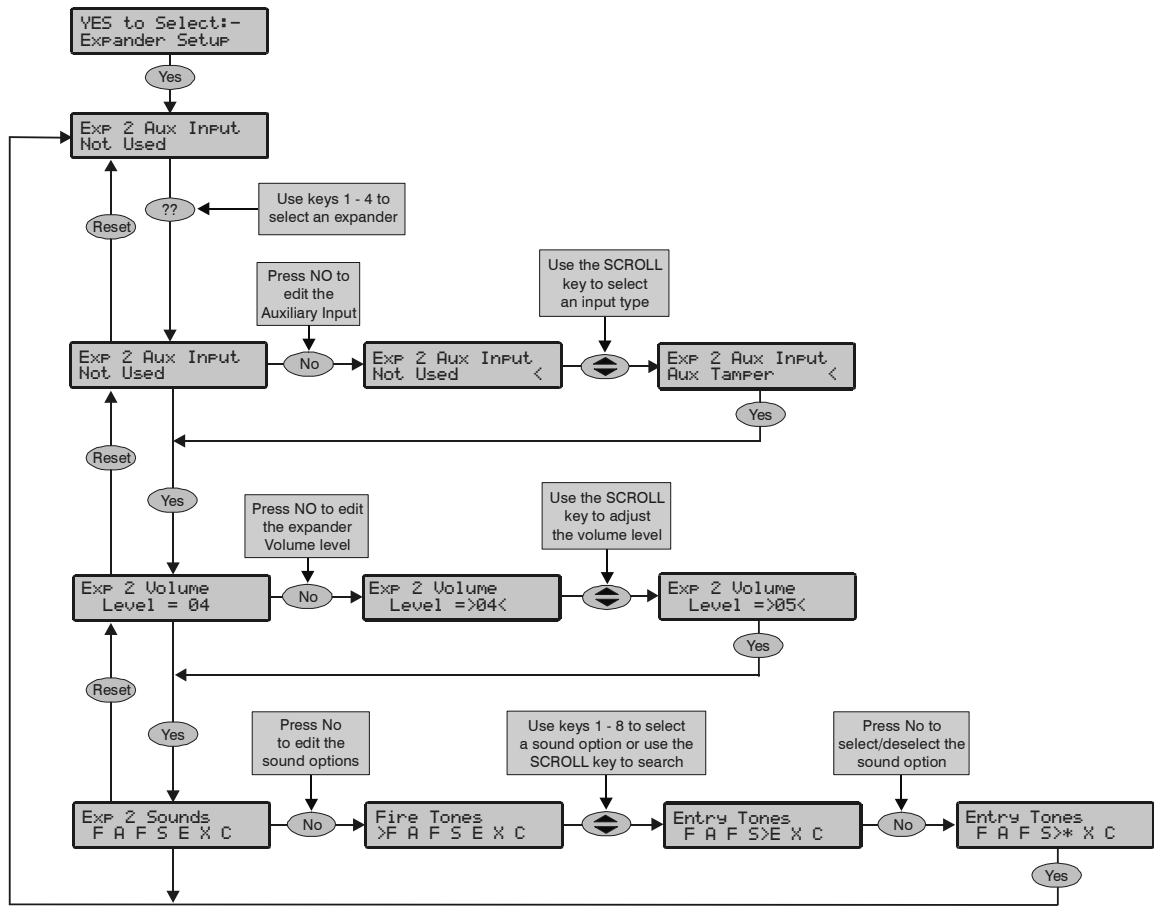

Expander Auxiliary Input

Each expander has an input that can be programmed for one of the following options. If not being used, the input must be programmed as 'Not Used' (Default = Not Used).

Not Used (Default)

Never monitored by the system.

Aux Tamper

Normally used for monitoring the box tamper of auxiliary devices such as power supplies etc (remove 0V for Tamper alarm).

Bell Tamper

Normally used for monitoring Bell Tamper returns (remove 0V for Tamper alarm).

Silence Sounders

Normally used to silence the Internal sounders following an Intruder alarm and would be used in conjunction with Audio Verification units (apply 0V to silence).

PSU Fault

Normally used for monitoring an external power supply for faults i.e. mains power off etc (remove 0V for mains fault).

Shunt Key

Normally wired to a key switch. When the input is 'Active' (0V applied), any zone with the 'Shunt' attribute will be isolated until the input returns to 'Secure' (0V removed).

Expander Speaker Volume

This option controls the volume level of advisory tones from loudspeakers connected to the expanders. Advisory tones consist of 'Entry/Exit' and 'Warning' type tones. 1 = minimum; 8 = maximum (Default = 5).



Alarm tones are always full volume.

Expander Sounder Options

The speaker output on the expander can be programmed so that certain types of tones are not generated. When deselected, Fire, Alarms, Fault, Service, Entry, Exit and Chime tones will not be heard.

Select tones by pressing keys 1 to 8 (a letter on the display means the tone is selected, a star on the display means the tone is not selected).

F - Fire Tones On (Default = ON)

Fire alarm tones will be generated by the expander sounder/speaker.

A - Alarm Tones On (Default = ON)

Intruder alarm, Tamper alarm and PA alarm tones will be generated by the expander sounder/speaker.

F - Fault Tones On (Default = ON)

Fault tones will be generated by the expander sounder/speaker.

S - Service Tone On (Default = ON)

Service and Warning tones will be generated by the expander sounder/speaker.

E - Entry Tones On (Default = ON)

Entry tones will be generated by the expander sounder/speaker.

X - Exit Tones On (Default = ON)

Exit tones will be generated by the expander sounder/speaker.

C - Chime Tones On (Default = ON)

Chime 1, 2 and 3 tones will be generated by the expander sounder/speaker.

Available Outputs

Various sets of programmable outputs can be found on the control panel, keypads, expanders and output modules.

Panel Outputs

Panel outputs 1 - 6 are located on the top right hand side of the control panel and can be programmed to any of the output types listed (see page 19 for wiring details).

Digi Channels

Digi channels 1 - 8 are for the *Com300*, *Com2400* and *ComISDN* plug-on digimodems and can be programmed to any of the output types listed.

PGM Outputs

PGM output 1 is located along the bottom edge of the control Panel. PGM outputs 2-8 are NOT physical outputs they are 'Software' outputs that can be configured to operate under certain conditions (see page 53 for details). Once configured these outputs can then be assigned to a physical output (see system output 25) or used to restrict code access (see page 69 for details).

Keypad Outputs

Keypad outputs are for the outputs on the remote keypads (see page 12 for details) and can be programmed to any of the output types listed. Wire as per Panel Outputs shown on page 19.

Expander Outputs

Expander outputs are for the outputs on the zone/output expanders (see page 14 for details) and can be programmed to any of the output types listed. Wire as per Panel Outputs shown on page 19.

Programming Outputs

When programming outputs, select an output group and an output type from that group's list (each output group has its own output types) then select attributes (if required).



Output Group + Output Type + Output Attributes = Output Programmed.

Output Group - Not Used

Only the following output type is available:

Not Used (off)

This output type never activates.

Output Group - System

Select an output type from the following options:

00 - Phone Line Fault

This output type activates when a telephone line fault is detected and deactivates when the fault is cleared.

01 - Mains Power Off

This output type activates when no AC Mains is detected on the control panel and deactivates when mains is detected

02 - Aux Fuse Blown

This output type activates when the Auxiliary PTC fails and deactivates when the system is reset.

03 - Bell Tamper

This output type activates when the control panel Bell tamper or an expander input (programmed as Bell tamper) is activated, causing a Tamper alarm on the system, and deactivates when the Tamper alarm is reset.

04 - Auxiliary Tamper

This output type activates when the control panel Aux tamper or an expander input (programmed as Auxiliary tamper) is activated, causing a Tamper alarm on the system, and deactivates when the Tamper alarm is reset.

05 - Panel Lid Tamper

This output type activates whenever the panel cover is removed, causing a Tamper alarm on the system, and deactivates when the Tamper alarm is reset.

06 - Engineer Working

This output type activates whenever an Engineer code is entered to access the programming menu and deactivates when the engineer logs off.

07 - Confirm Devices

This output type activates when the control panel requires devices to be confirmed and deactivates when the devices are confirmed (see page 74 for details).

08 - Service Required

This output type activates when the 'Service Interval' timer expires and deactivates when an Engineer code is entered (see page 39 for details).

09 - Shunt Active

This output type activates whenever zones with the 'Shunt' attribute are isolated using either a 'Shunt' code or a 'Shunt' key. And deactivates when the zones are reinstated.

10 - Battery Fault

This output type activates when the system detects a fault with the stand-by battery, and deactivates when the fault clears.

11 - Battery Test On

This output type activates when the 'Battery Test' starts, and deactivates when the test expires (see page 39 for details).

12 - Courtesy Light

This output type activates when the 'Courtesy' timer starts, and deactivates when the timer expires (see page 39 for details).

13 - PC Control 1

This output can be activated and deactivated using the *Wintex UDL* software or the *GSM Module* text facility.

14 - PC Control 2

This output can be activated and deactivated using the *Wintex UDL* software or the *GSM Module* text facility.

15 - Coms Failed

This output type activates when the plug-on digimodem fails to report to the Alarm Receiving Centre (after 3 dialling attempts), and deactivates the next time the digimodem successfully reports to the Alarm Receiving Centre.

16 - Coms Successful

This output type activates when the plug-on digimodem successfully reports to the Alarm Receiving Centre and deactivates the next time the digimodem is triggered.

17 - Coms Active

This output type activates when the plug-on digimodem is triggered and deactivates when the digimodem shuts down.

18 - UDL Lockout

This output type activates when an attempt is made to upload/download with incorrect site details more than three times and deactivates after 4 hours or after a valid User code is entered.

19 - UDL Call Active

This output type activates when an upload/download is started and deactivates when the upload/download finishes.

20 - UDL Enabled

This output type activates when 'Enable UDL/Engineer' is enabled and deactivates when 'Enable UDL/Engineer' is disabled.

21 - Custom Output

This output type activates when 'PGM 5 OR 6 AND 7 AND 8' activate and deactivates when 'any one of the same PGM outputs deactivate (see page 53 for details).

22 - Activity Fault

This output type activates whenever a zone with the 'Activity' attribute has not activated and deactivates when the zone activates.

23 - No Battery

This output type activates for 1 minute if the engineer logs off the control panel and there is no battery fitted.

24 - Control Timer 1

This output type operates when 'Control Timer 1' activates and deactivates when 'Control Timer 1' deactivates.

25 - Control Timer 2

This output type operates when 'Control Timer 2' activates and deactivates when 'Control Timer 2' deactivates.

26 - Control Timer 3

This output type operates when 'Control Timer 3' activates and deactivates when 'Control Timer 3' deactivates.

27 - Control Timer 4

This output type operates when 'Control Timer 4' activates and deactivates when 'Control Timer 4' deactivates.

28 - Com Port 1 Fault

This output type activates when whatever is connected to Com Port 1 stops communicating with the control panel and deactivates when communication starts again.

29 - Com Port 2 Fault

This output type activates when whatever is connected to Com Port 2 stops communicating with the control panel and deactivates when communication starts again.

30 - Code Accepted

This output type activates for 5 seconds whenever a User code is entered.

31 - Prox TAG Accepted

This output type activates for 5 seconds whenever a Proximity TAG is presented.

Output Group - Alarm

Select an output type from the following options:

00 - Alarm

This output type activates when a general alarm condition occurs, and deactivates when the alarm is cancelled.

01 - Guard Alarm

This output type activates when a zone programmed as 'Guard' causes an Intruder alarm and deactivates when the alarm is cancelled.

02 - Guard Access Alarm

This output type activates when a zone programmed as 'Guard Access' causes an Intruder alarm and deactivates when the alarm is cancelled.

03 - Entry Alarm

This output type activates when a zone programmed as 'Entry/Exit 1 or 2' causes an Intruder alarm and deactivates when the alarm is cancelled.

04 - Confirmed Alarm

If the system is already in alarm, this output type activates when a different zone (not on the entry route) is activated and deactivates at the end of the 'Confirmation' time, when a code is entered within the 'Abort' time or when the alarm is reset.

05 - 24Hr Audible

This output type activates when a zone programmed as '24Hr Audible' causes an Internal alarm or Intruder alarm and deactivates when the alarm is cancelled.

06 - Trouble

This output type activates when a zone programmed as 'Trouble' causes an alarm and deactivates when the alarm is cancelled.

07 - 24Hr Gas

This output type activates when a zone programmed as '24Hr Gas' causes a Silent alarm or Intruder alarm and deactivates when the alarm is cancelled.

08 - PA Alarm

This output type activates when any type of 'PA alarm' i.e. PA audible, PA silent or Duress causes a PA alarm and deactivates when the alarm is cancelled.

09 - PA Silent

This output type activates when a zone programmed as 'PA Silent' or a keypad PA (1 & 3) causes a silent PA alarm and deactivates when the alarm is cancelled.

10 - Duress

This output type activates when a User code with the 'Duress' attribute causes a silent PA alarm and deactivates when the alarm is cancelled.

11 - Fire Alarm

This output type activates when a zone programmed as 'Fire' or a keypad Fire (4 & 6) causes a Fire alarm and deactivates when the alarm is cancelled.

12 - Medical

This output type activates when a zone programmed as 'Medical' or a keypad Medical (7 & 9) causes a Medical alarm and deactivates when the alarm is cancelled.

13 - Auxiliary Alarm

This output type activates when a zone programmed as 'Auxiliary' causes a Silent alarm and deactivates when the alarm is cancelled.

14 - Tamper Alarm

This output type activates when a Tamper alarm is generated and deactivates when the alarm is cancelled.

15 - Alarm Abort

This output type activates when a User code is entered to cancel the alarm (within the 'Abort Delay' period and deactivates after 10 seconds.

16 - Ready

This output type activates when all zones are secure and deactivates when any zone is active.

17 - Entry Mode

This output type activates when the entry mode is started and deactivates when the entry mode finishes.

18 - 2nd Entry Mode

This output type activates when the 2nd entry timer starts and deactivates when the 2nd entry timer expires.

19 - Exit Mode

This output type activates when the exit mode is started and deactivates when the exit mode finishes.

20 - Entry/Exit Mode

This output type activates when the entry or exit mode is started and deactivates when the entry or exit mode finishes.

21 - Armed

This output type activates when the system is armed and deactivates when the system is disarmed.

22 - Full Armed

This output type activates when the system is fully armed and deactivates when the system is not fully armed.

23 - Part Armed

This output type activates when the system is part armed and deactivates when the system is not part armed.

24 - Force Arm

This output type activates when there is at least one zone with the 'Force Omit' attribute assigned to it, and deactivates when there are no zones with the 'Auto Omit' attribute assigned to it.

25 - Force Arming

This output type activates when the system has been forced to arm with zones active, and deactivates when the zone is reinstated.

26 - Arm Failed

This output type activates when the system fails to arm because a zone is in fault, and deactivates when the fault is reset.

27 - Bell SAB

This output type activates when an Alarm occurs and deactivates when the alarm is cancelled or the 'Bell Duration' timer expires.

28 - Strobe

This output type activates when an Alarm occurs and deactivates when the alarm is cancelled or the system is disarmed

29 - Detector Latch

This output type activates for 5 seconds when the exit mode is started then reactivates when the system arms. The output type deactivates when an Intruder alarm occurs or the system is disarmed.

30 - Detector Reset

This output type is normally active and deactivates for 5 seconds when the exit mode is started.

31 - Walk Test Active

This output type activates when the 'Walk Test' procedure is started, and deactivates when the 'Walk Test' procedure is finished.

32 - Zones Omitted

This output type activates when a zone with the 'Omit' attribute, is omitted, and deactivates when the zone is reinstated.

33 - 24Hr Zones Omit

This output type activates when a zone programmed as '24Hr Audible' (with the 'Omit' attribute) is omitted by the user and deactivates when the zone is reinstated.

34 - Reset Required

This output type activates when the system requires a reset following an alarm and deactivates when the alarm is reset.

35 - Door Strike

This output type activates for the duration of the 'Door Strike' timer when a User code with the 'Door Strike' attribute is entered.

36 - Chime Mimic

This output type activates for 2 seconds when a zone with the 'Chime' attribute is activated.

37 - Chime Enabled

This output type activates when 'Chime' is enabled and deactivates when 'Chime' is disabled.

38 - DK First Knock

This output type activates when a zone with the 'Double Knock' attribute is activated for the first time and deactivates when the zone causes an alarm or the 'Double Knock Delay' timer expires.

39 - On Test

This output type activates when a zone with the 'Test' attribute is placed on test and deactivates when the 'Soak Test Time' expires.

40 - Test Fail

This output type activates when a zone with the 'Test' attribute activates and deactivates when an Engineer code is entered.

41 - Internal Alarm

This output type activates when an Internal alarm occurs and deactivates when the alarm is cancelled.

42 - Time Arming

This output type activates for 5 minutes prior to the system being armed using the 'Control Timers'.

43 - Part Armed 1

This output type activates when a Part Arm 1 is selected and deactivates when part arm 1 is not selected.

44 - Part Armed 2

This output type activates when a Part Arm 2 is selected and deactivates when part arm 2 is not selected.

45 - Part Armed 3

This output type activates when a Part Arm 3 is selected and deactivates when part arm 3 is not selected.

46 - Zones Locked Out

This output type activates when any zone is locked out following an Intruder Alarm activation and deactivates when all zones are clear and reinstated.

47 - Armed/Alarm

This output type activates when the system is armed and deactivates when the system is disarmed

This output type also pulses when an Intruder alarm occurs, and deactivates when the system is disarmed.

48 - Full Arm Entry

This output type activates when the entry mode is started and deactivates when the entry mode finishes whenever the system in Full Armed.

49 - Intruder Alarm

This output type activates when an Intruder alarm occurs, and deactivates when the Intruder alarm is cancelled.

Tamper alarms will not activate this output

Output Group - Zone

Any zone can be assigned to each output type. Select a zone number from 1 to 48 (*Premier 48*), 1 to 88 (*Premier 88*) or 1 to 168 (*Premier 168*) then select an output type from the following options:

Mimic

This output type activates when the selected zone is activated and deactivates when the zone is secure. This output will work if the zone is armed or disarmed.

Alarm

This output type activates when the selected zone causes an alarm and deactivates when the alarm is reset. This output will only work if the zone is armed.

Output Attributes

Assigning an attribute to an output will alter how the output works. The following attributes can be assigned to any of the various types listed.



Select attributes by pressing keys 1 to 4 (a letter on the display means the attribute is selected, a star on the display means the attribute is not selected).

U - User Test

The output will activate when a user performs a User test (see page 73 for details).

I - Inverted

The output is inverted (an output that applies 0V when active will become an output that applies 12V when active).

L - Latching

When activated, the output will remain on until a valid User code is entered.

1 - Pulsed

When activated, the output will remain on for the duration of the 'Pulse Period 1' timer (see page 39 for details).

Custom Output (PGM5-8)

Custom outputs are NOT physical outputs they are 'Software outputs that can be configured to operate under certain conditions. Once configured these outputs can then be assigned to a physical output (see system output 21, page 51 for details).

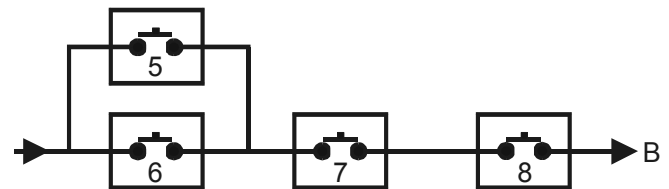
**Example**

PGM5 is programmed as: **Zone 1 Mimic**

PGM6 is programmed as: **Zone 2 Mimic**

PGM7 is programmed as: **Armed**

PGM8 is programmed as: **Never Active (and inverted)**



The Custom Output will only activate when switches 1 OR 2 AND 3 AND 4 are closed.

i.e. if ZONE 1 or ZONE 2 ACTIVATES whilst the system is ARMED (switch 4 is always closed).

6.7 UDL/Digi Options

Reset Digi

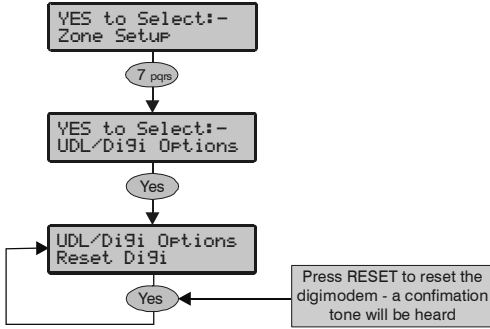

This option should be used whenever a *Premier* plug-on communicator is plugged on or removed from the control panel.

Start Test Call

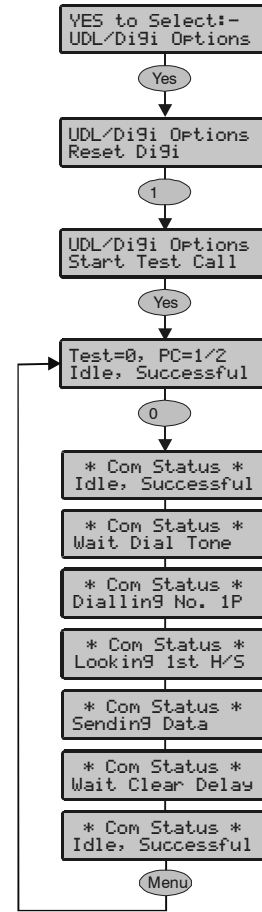

When a *Premier* plug-on communicator has been fitted to the control panel. This option can be used to send a test call to the Alarm Receiving Centre or to initiate a remote Upload/Download call to one of the programmed callback numbers.

Program Digi

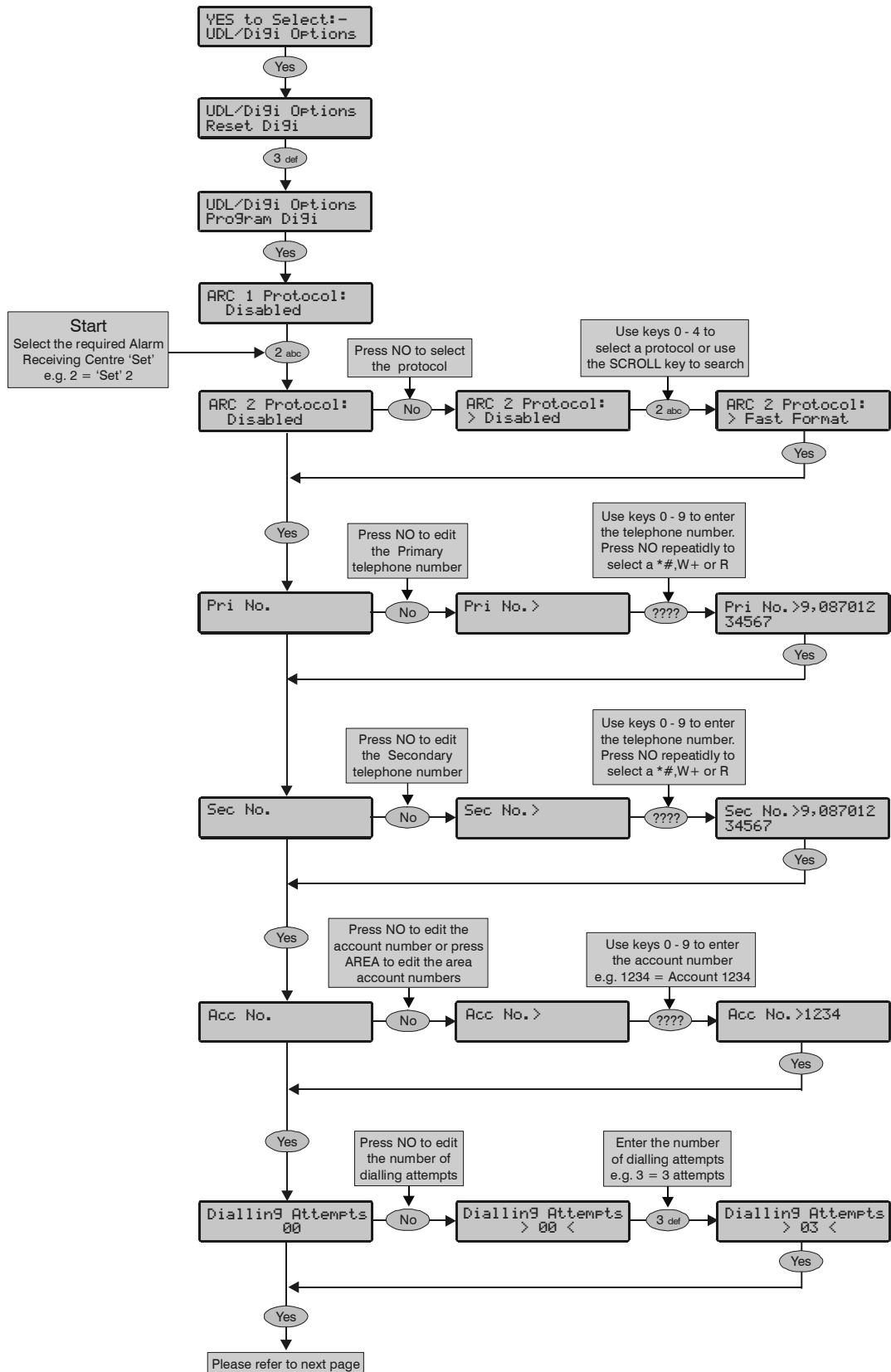

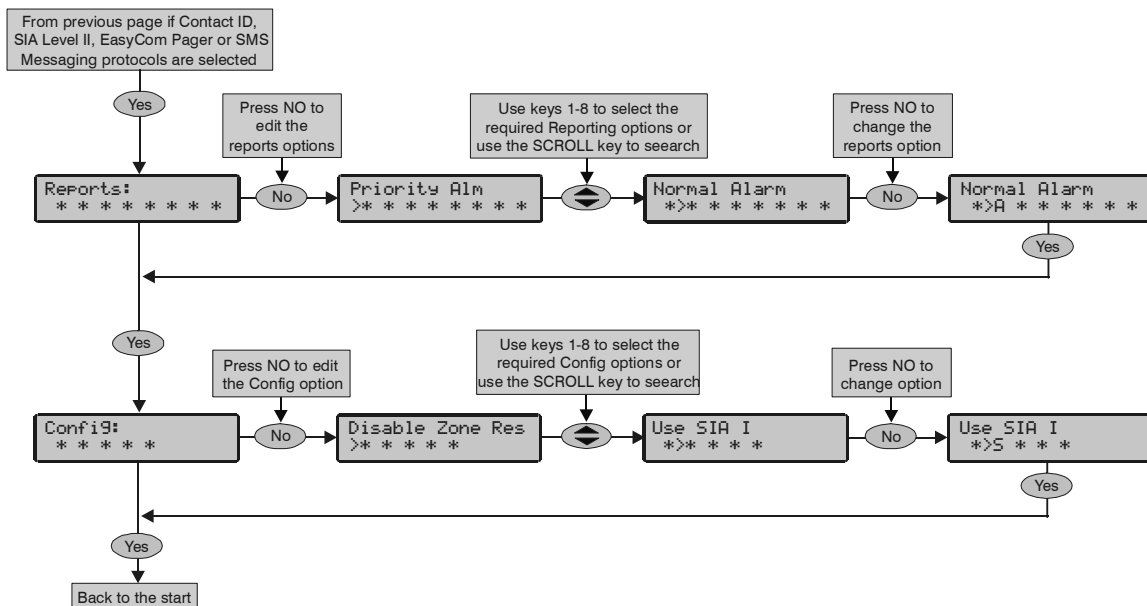
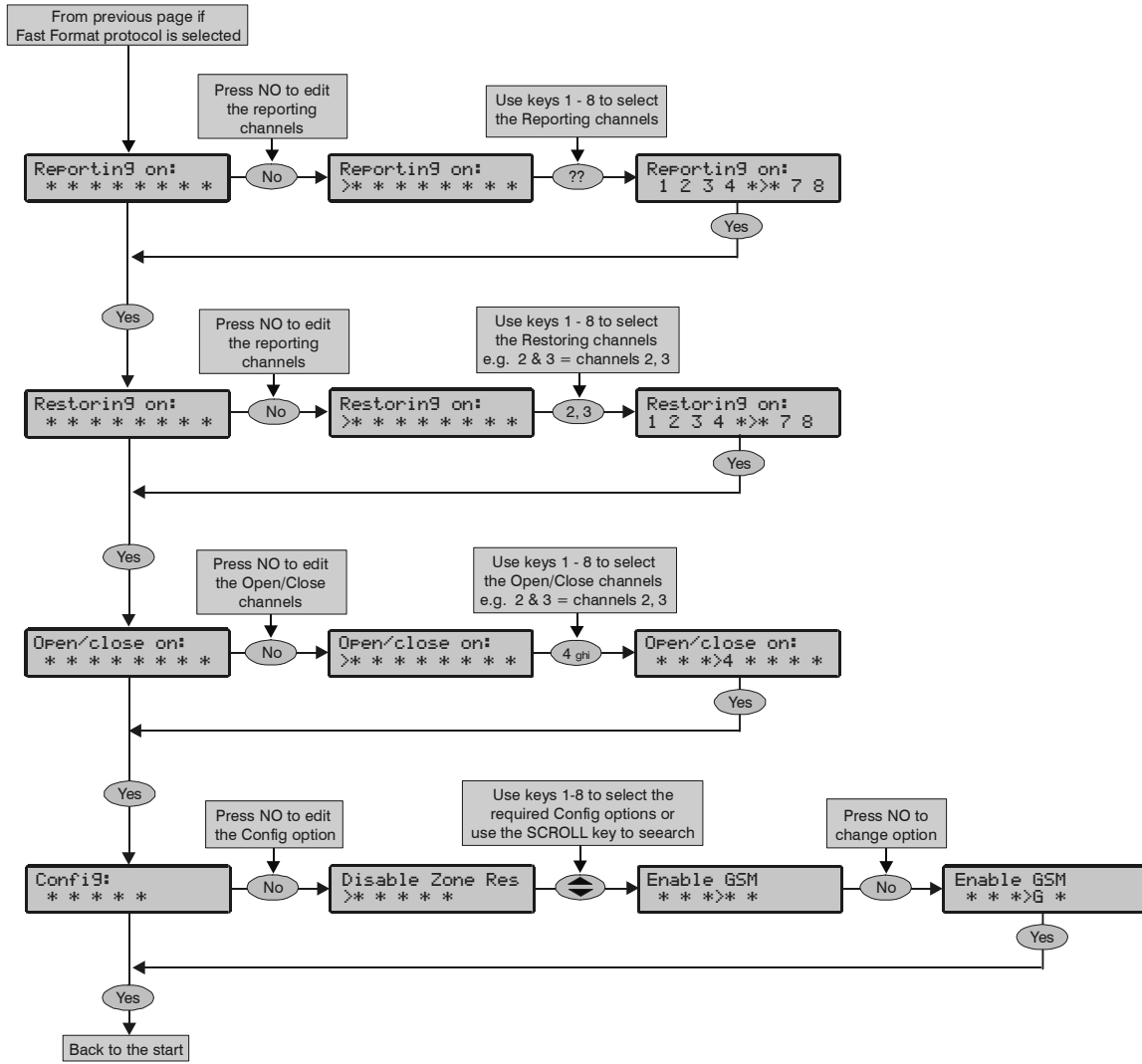

The plug-on digimodem can be programmed with up to 2 sets of Alarm Receiving Centre (ARC) information. Each 'Set' consists of the following options:

Protocol

This is the reporting protocol that is used to communicate with the Alarm Receiving Centre. The following 4 protocols are supported:

- **Fast Format:** The panel will report using Fast Format. If this option is selected the 'Reporting Channels' must be programmed (see below)
- **Contact ID:** The panel will report using Contact ID.
- **SIA Level II:** The panel will report using SIA Level II
- **SMS Messaging:** The panel will send Short Message Service (SMS) text messages to a mobile phone

Primary Telephone Number

This is the first telephone number that the digimodem will dial for the Alarm Receiving Centre or the first mobile telephone number to send SMS to. This telephone number can be up to 24 digits.

When entering telephone numbers, pressing  repeatedly will allow the following characters to be selected:

*#, (3 second pause) W (10 second pause) + R (recall signal).

Secondary Telephone Number

This is the second telephone number that the digimodem will dial for the Alarm Receiving Centre or the second mobile telephone number to send SMS to. This telephone number can be up to 24 digits.

Account Number

This is the account number that will be reported to the Alarm Receiving Centre. Each account number can be up to 6 digits.

Dialling Attempts

This is the number of times the digimodem will try to dial the Alarm Receiving Centre or Pager telephone number.



The number of dialling attempts is limited to 9. If this value is set to 0, the digimodem will never dial out.

The following option is only displayed if the Fast Format protocol is selected

Reporting on

This option defines which channels report to the selected Alarm Receiving Centre.

Restoring on

This option defines which channels report a restore to the selected Alarm Receiving Centre.

Open/Close on

This option defines which channels report Open/Close to the selected Alarm Receiving Centre.

The following option is only displayed if Contact ID, SIA Level II or EasyCom Pager protocols are selected

Reports

This option defines which events report to the Alarm Receiving Centre when using Contact ID or SIA Level II. The following options are available:

P - Priority Alarm and Cancel Events

The system will report Priority alarm and cancel events to the selected Alarm Receiving Centre.

A - Normal Alarm and Cancel Events

The system will report alarm and cancel events to the selected Alarm Receiving Centre.

O - Open and Close Events

The system will report open and close events to the selected Alarm Receiving Centre.

O - Omit and Reinstate Events

The system will report omit and reinstate events to the selected Alarm Receiving Centre.

M - Maintenance Alarm Events

The system will report maintenance alarm events to the selected Alarm Receiving Centre.

T - Tamper Alarm Events

The system will report tamper alarm events to the selected Alarm Receiving Centre.

C - Test Call Events

The system will report test call events to the selected Alarm Receiving Centre.

R - Restore Events

The system will report restore events to the selected Alarm Receiving Centre.

The following option is only displayed if Fast Format Contact ID or SIA Level II protocols are selected

Config.

This option defines which secondary options are enabled. The following options are available:

D - Disable Zone Res

The system will NOT report zone restore events to the selected Alarm Receiving Centre.

S - SIA Level I

The system will report events to the selected Alarm Receiving Centre using SIA Level I.

R - Enable Radio-Pad

The system will use the Paknet radio-pad to report events to the selected Alarm Receiving Centre.

G - Enable GSM Module

The system will use the GSM Module to report events to the selected Alarm Receiving Centre (see page 5 for details).

F - Use GSM First

The GSM module is the primary path when it is enabled

Digi Options

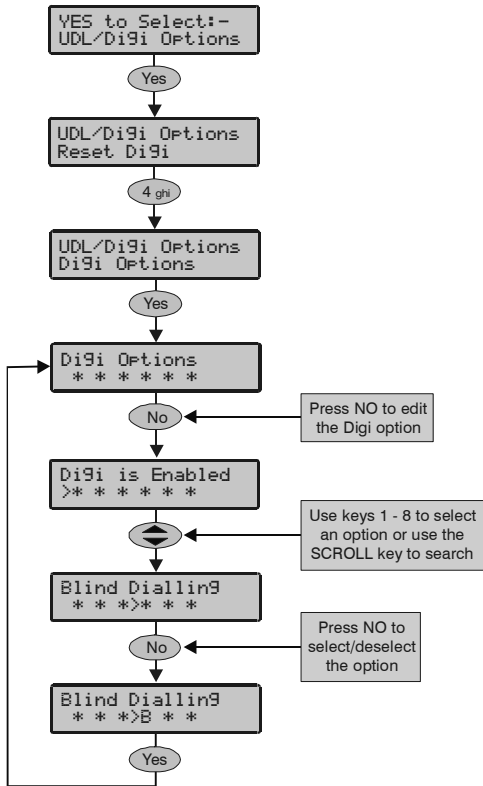

There are 5 options that control how the plug-on Digimodem works.

Select options by pressing keys 1 to 8 (a letter on the display means the option is selected, a star on the display means the option is not selected).

E – Digi is Enabled (Default = OFF)

The plug-on Digimodem will report all system events to the Alarm Receiving Centre.

P – Pulse Dialling (Default = OFF)

The plug-on Digimodem will always dial telephone numbers using pulse dialling.

3 – Pulse After 3 (Default = OFF)

The plug-on Digimodem will always dial telephone numbers using tone dialling. However, if the Digimodem fails to dial the number three times in a row, it will revert to pulse dialling for the remaining attempts.

B – Blind Dialling (Default = OFF)

The plug-on Digimodem will not look for a dial tone before dialling a telephone number.

R – Reserved (Default = OFF)

This option is not used.

A – Dial All Numbers (Default = OFF)

The Digimodem will not shut down until an acknowledgement has been received from all programmed telephone numbers.

UDL Options

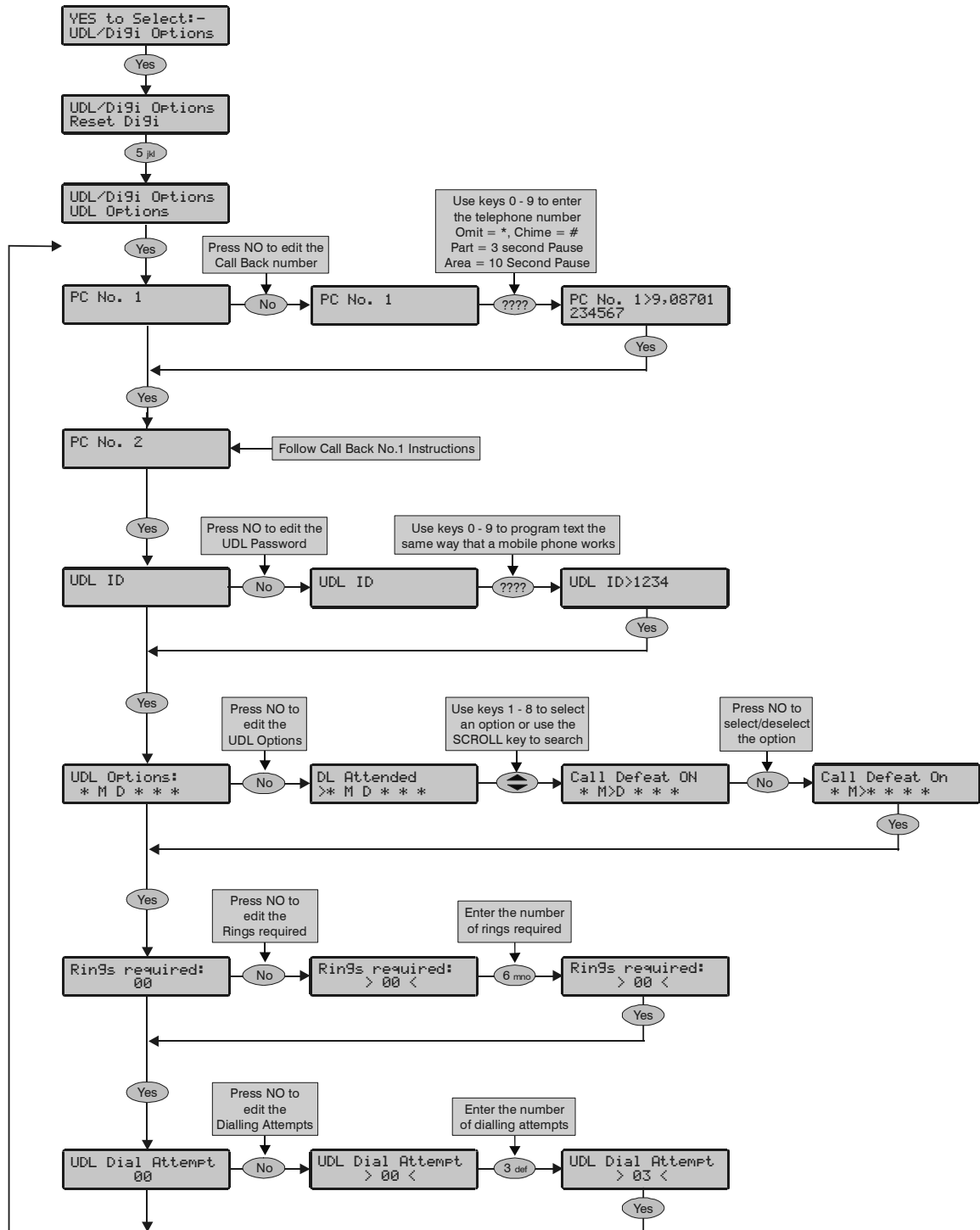

The system has the following download options:

PC No. 1

This is the telephone number that is dialled by the modem when 'Call-back Number 1' is requested by the remote UDL computer.

When entering telephone numbers, pressing  repeatedly will allow the following characters to be selected:

*#, (3 second pause)W(10 second pause)+R(recall signal).

PC No. 2

This is the telephone number that is dialled by the modem when 'Call-back Number 2' is requested by the remote UDL computer.

UDL ID:

When the remote downloading computer dials into the system, the control panel compares the UDL password sent by the computer with UDL password stored in the control panel. If the passwords match, access to the control panel is granted, if they don't match, access is denied.



If more than three attempts at reporting are made with a wrong password, the modem will lock out for 4 hours or until a User code is entered.

The UDL password programmed in this option must also be programmed in the customer account on the remote downloading computer. This password can be up to 16 characters (numbers and letters).

If no UDL Password has been programmed, access to the control panel can be gained by using the engineers code as the UDL Password.

UDL Options

There are 6 UDL options that affect how and when access to the control panel via the *Wintex UDL* software is allowed.

Select options by pressing keys 1 to 6 (a letter on the display means the option is selected, a star on the display means the option is not selected).

The following UDL options are available:

A - DL Attended (Default = OFF)

The system will not allow the remote downloading computer access without for user authorisation first.

M - Man Call-Back (Default = ON)

The system will not use the automatic call back feature. The user must instruct the panel to call back the remote downloading computer.

The Auto Call-Back feature operates as follows:

- The remote downloading computer calls the control panel and establishes a connection
- The UDL password is verified and the remote downloading computer instructs the panel to call it back using one of the 3 call back numbers
- The panel hangs up and dials the requested number and re-establishes the connection with the remote downloading computer

D - Call Defeat (Default = ON)

The modem will answer incoming calls as follows:

- The modem must detect one or more rings and the number of rings must NOT exceed the value set up in 'Rings Required'
- When the ringing stops, the panel will start a 30 second delay timer
- If the modem detects ringing before the timer expires it will answer the call immediately

L - Armed DL Limited (Default = OFF)

The panel will not allow download access when the system is armed (also see below).

A - Only Full Armed (Default = OFF)

The panel will not allow download access when the system is fully armed.

K - Online RKP=Off (Default = OFF)

The control panel cannot be accessed using the 'On-line' keypad feature of the *Wintex UDL* software.

Rings Required

This counter controls the number of rings the modem needs to see before it will answer the call (Default = 005).

UDL Dial Attempt

If a 'Call-Back' is started, this option controls how many times the modem will try to call the remote downloading computer before giving up (Default = 003).



Enter the number of dialling attempts. This number is limited to 9. If this value is set to 0, the Digimodem will never dial out.

This only affects the modem for download access and does not affect the operation of the Digimodem in any way.

Radio/SMS Options

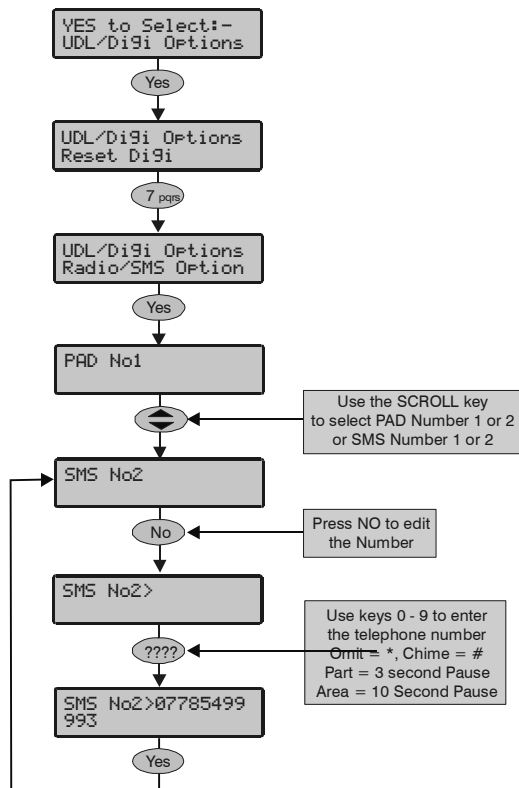

Pad ARC 1 Pri No

This is the first number that is used by the Radio-Pad for reporting events to ARC set 1.

Pad ARC 1 Sec No

This is the second number that is used by the Radio-Pad for reporting events to ARC set 1.

Pad ARC 1 Prefix

This number will prefix the account number for ARC 1.

Pad ARC 2 Pri No

This is the first number that is used by the Radio-Pad for reporting events to ARC set 2.

Pad ARC 2 Sec No

This is the second number that is used by the Radio-Pad for reporting events to ARC set 2.

Pad ARC 2 Prefix

This number will prefix the account number for ARC 2.

SMS Centre Pri.

This is the first SMS centre telephone number that is used by for sending SMS to mobile phones. (Default = 07860 980480).

SMS Centre Sec.

This is the second SMS centre telephone number that is used by for sending SMS to mobile phones.

Com Port Setup

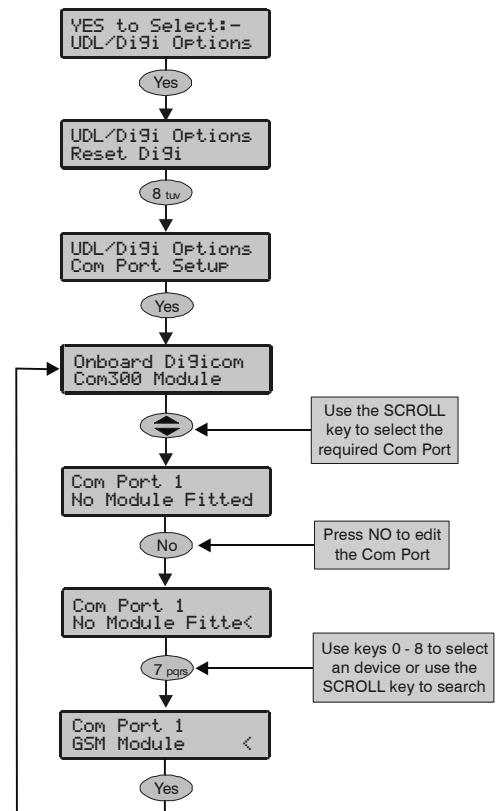

The control panel must be programmed with the type of device that is connected to each of its com ports.

Onboard Digicom

This option determines what type of device is connected to the plug-on digimodem connector (Default = Com300).

Com1

This option determines what type of device is connected to the Com1 connector (Default = No Module Fitted).

Com2

This option determines what type of device is connected to the Com2 connector (Default = No Module Fitted).

Available Device Types

No Module Fitted
Com300
Com2400
ComISDN
Paknet Radio-Pad
GSM Module

Zone Alarm Reporting Codes

The Reporting codes for Contact ID and SIA are fully configurable, however these codes can only be changed using *Wintex* downloading software.

The following tables show the default codes for each event on the system:

Default Zone Event Codes

No	Zone Type	Event	Reporting Group	Contact ID	SIA
00	Entry/Exit 1	Alarm	Alarm	134	BA
		Alarm Restore	Restore	134	BH
		Omit	Omit/Reinstate	573	BB
		Reinstate	Omit/Reinstate	573	BU
01	Entry/Exit 2	Alarm	Alarm	134	BA
		Alarm Restore	Restore	134	BH
		Omit	Omit/Reinstate	573	BB
		Reinstate	Omit/Reinstate	573	BU
02	Guard	Alarm	Alarm	132	BA
		Alarm Restore	Restore	132	BH
		Omit	Omit/Reinstate	573	BB
		Reinstate	Omit/Reinstate	573	BU
03	Guard Access	Alarm	Alarm	132	BA
		Alarm Restore	Restore	132	BH
		Omit	Omit/Reinstate	573	BB
		Reinstate	Omit/Reinstate	573	BU
04	24Hr Audible	Alarm	Tamper	133	BA
		Alarm Restore	Restore	133	BH
		Omit	Omit/Reinstate	572	BB
		Reinstate	Omit/Reinstate	572	BU
05	Forced Entry	Alarm	Tamper	133	BA
		Alarm Restore	Restore	133	BH
		Omit	Omit/Reinstate	572	BB
		Reinstate	Omit/Reinstate	572	BU
06	Audible PA	Alarm	Priority Alarm	123	PA
		Alarm Restore	Restore	123	PH
		Omit	Omit/Reinstate	573	PB
		Reinstate	Omit/Reinstate	573	PU
07	Silent PA	Alarm	Priority Alarm	122	HA
		Alarm Restore	Restore	122	HH
		Omit	Omit/Reinstate	573	HB
		Reinstate	Omit/Reinstate	573	HU
08	Fire Alarm	Alarm	Priority Alarm	110	FA
		Alarm Restore	Restore	110	FH
		Omit	Omit/Reinstate	571	FB
		Reinstate	Omit/Reinstate	571	FU
09	24Hr Gas Alarm	Alarm	Tamper	151	GA
		Alarm Restore	Restore	151	GH
		Omit	Omit/Reinstate	572	GB
		Reinstate	Omit/Reinstate	572	GU

No	Zone Type	Event	Reporting Group	Contact ID	SIA
10	Auxiliary Alarm	Alarm	Tamper	150	UA
		Alarm Restore	Restore	150	UH
		Omit	Omit/Reinstate	572	UB
		Reinstate	Omit/Reinstate	572	UU
11	24Hr Tamper Alarm	Alarm	Tamper	137	TA
		Alarm Restore	Restore	137	TR
		Omit	Omit/Reinstate	572	TB
		Reinstate	Omit/Reinstate	572	TU
12	Exit Terminator	Alarm	Open/Close	---	--
		Alarm Restore	Open/Close	---	--
		Omit	Omit/Reinstate	570	UB
		Reinstate	Omit/Reinstate	570	UU
13	Keyswitch	Alarm	Open/Close	409	OP
		Alarm Restore	Open/Close	409	CL
		Omit	Omit/Reinstate	570	UB
		Reinstate	Omit/Reinstate	570	UU

Non-Zone Event Types

The default Non-Zone Event codes are as follows:

No	Type	Event	Reporting Group	Contact ID	SIA	ID
20	Keypad Medical	Alarm	Priority Alarm	100	MA	Keypad No *
		Restore	Restore	100	MH	Keypad No *
21	Keypad Fire	Alarm	Priority Alarm	115	FA	Keypad No *
		Restore	Restore	115	FH	Keypad No *
22	Keypad Audible PA	Alarm	Priority Alarm	120	PA	Keypad No *
		Restore	Restore	120	PH	Keypad No *
23	Duress Code Alarm	Alarm	Priority Alarm	122	HA	User No
		Restore	Restore	122	HH	User No
24	Keypad Silent PA	Alarm	Priority Alarm	121	PA	Keypad No *
		Restore	Restore	121	PH	Keypad No *
25	Alarm Active	Alarm	-	-	-	-
		Restore	-	-	-	-
26	Bell Active	Alarm	-	-	-	-
		Restore	-	-	-	-
27	Re-arm	Alarm	Alarm	-	-	Zone No
		Restore	-	-	-	-
28	Verified Cross Zone Alarm	Alarm	Alarm	130	BV	00
		Restore	-	-	-	-
29	User Code	Alarm	-	-	-	User No
		Restore	-	-	-	-
30	Exit Started	Alarm	-	-	-	Keypad No
		Restore	-	-	-	-
31	Exit Error (Arming Failed)	Alarm	Open/Close	457	EE	00
		Restore	-	-	-	-
32	Entry Started	Alarm	-	-	-	-
		Restore	-	-	-	-
33	Area Arm Suite	Alarm	Open/Close	-	-	Suite No 1 – 8
		Restore	Open/Close	-	-	-

No	Type	Event	Reporting Group	Contact ID	SIA	ID
34	Armed with Line Fault	Alarm	-	-	-	User No
		Restore	-	-	-	-
35	Open/Close (Full Arm)	Alarm	Open/Close	401	OP	User No
		Restore	Open/Close	401	CL	User No
36	Open/Close (Part Arm)	Alarm	Open/Close	401	OP	User No
		Restore	Open/Close	401	CL	User No
37	Auto Open/Close	Alarm	Open/Close	403	OA	00
		Restore	Open/Close	403	CA	00
38	Auto Arm Deferred	Alarm	Open/Close	405	CE	User No
		Restore	Open/Close	-	-	-
39	Open After Alarm (Alarm Abort)	Alarm	Open/Close	406	OR	00
		Restore	-	-	-	-
40	Remote Open/Close	Alarm	Open/Close	407	OP	00
		Restore	Open/Close	407	CL	00
41	Quick Arm	Alarm	-	-	-	-
		Restore	Open/Close	408	CL	Keypad No *
42	Recent Closing	Alarm	Open/Close	459	CR	00
		Restore	-	-	-	-
43	Reset After Alarm	Alarm	Restore	-	-	Reset ID ****
		Restore	-	-	-	-
44	Auxiliary 12V Fuse Fail	Alarm	Maintenance	300	YP	Device ID **
		Restore	Restore	300	YQ	Device ID **
45	AC Fail	Alarm	Maintenance	301	AT	00
		Restore	Restore	301	AR	00
46	Low Battery	Alarm	Maintenance	302	YT	00
		Restore	Restore	302	YR	00
47	System Power Up	Alarm	Maintenance	305	RR	00
		Restore	-	-	-	-
48	Bell Fuse Failure	Alarm	Maintenance	321	YA	00
		Restore	Restore	321	YH	00
49	Telephone Line Fault	Alarm	Maintenance	351	LT	Line Fault ID ***
		Restore	Restore	351	LR	Line Fault ID ***
50	Fail to Communicate	Alarm	Maintenance	354	YC	00
		Restore	-	-	-	-
51	Reporting Successful	Alarm	-	-	-	-
		Restore	-	-	-	-
52	Communicator Active	Alarm	-	-	-	-
		Restore	-	-	-	-
53	Download Start	Alarm	Maintenance	411	RB	00
		Restore	-	-	-	-
54	Download End	Alarm	Maintenance	412	RS	-
		Restore	-	-	-	-
55	Log Capacity Alert (80%)	Alarm	Maintenance	623	JL	00
		Restore	-	-	-	-
56	Date Changed	Alarm	Maintenance	625	JD	User No
		Restore	-	-	-	-

No	Type	Event	Reporting Group	Contact ID	SIA	ID
57	Time Changed	Alarm	Maintenance	625	JT	User No
		Restore	-	-	-	-
58	Installer Programming Start	Alarm	Maintenance	627	LB	User No
		Restore	-	-	-	-
59	Installer Programming End	Alarm	Maintenance	628	LS	User No
		Restore	-	-	-	-
60	Panel Box Tamper	Alarm	Tamper	145	TA	00
		Restore	Restore	145	TR	00
61	Bell Tamper	Alarm	Tamper	145	TA	Device ID **
		Restore	Restore	145	TR	Device ID **
62	Auxiliary Tamper	Alarm	Tamper	145	TA	Device ID **
		Restore	Restore	145	TR	Device ID **
63	Expander Tamper	Alarm	Tamper	145	TA	Device ID **
		Restore	Restore	145	TR	Device ID **
64	Keypad Tamper	Alarm	Tamper	145	TA	Keypad No *
		Restore	Restore	145	TR	Keypad No *
65	Expander Trouble (Network Error)	Alarm	Tamper	333	ET	Device ID **
		Restore	Restore	333	ER	Device ID **
66	Keypad Trouble (Network Error)	Alarm	Tamper	333	ET	Keypad No *
		Restore	Restore	333	ER	Keypad No *
67	Fire Zone Tamper	Alarm	Tamper	373	FT	Zone No
		Restore	Restore	373	FJ	Zone No
68	Zone Tamper	Alarm	Tamper	383	TA	Zone No
		Restore	Restore	383	TR	Zone No
69	Keypad Lockout	Alarm	Tamper	421	JA	Keypad No *
		Restore	-	-	-	-
70	Code Tamper Alarm	Alarm	Tamper	421	JA	Keypad No *
		Restore	-	-	-	-
71	Soak Test Alarm	Alarm	Test	-	-	Zone No
		Restore	Restore	-	-	Zone No
72	Manual Test Call	Alarm	Test	601	RX	00
		Restore	-	-	-	-
73	Automatic Test Call	Alarm	Test	602	RP	00
		Restore	-	-	-	-
74	User Walk Test Start/End	Alarm	Test	607	TS	User No
		Restore	Restore	607	TE	User No

Keypad No *

Keypad ID is transmitted as follows:

Remote Keypad	Network 1	Network 2
1	101	201
2	102	202
3	103	203
4	104	204

Line Fault ID ***

Line Fault ID is transmitted as follows:

Device	ID
Panel	000
Com300	003
Expander 1	001
Expander 2	002

Device ID **

Device ID is transmitted as follows:

Device	ID	
Panel	000	
	Net 1	Net 2
Expander 1	101	201
Expander 2	102	202

Reset ID ****

Reset ID is transmitted as follows:

Device	ID
Engineer/User	000
Panel (RR)	001
RedCARE	002
Expander 1	001
Expander 2	002

6.8 Setup Users

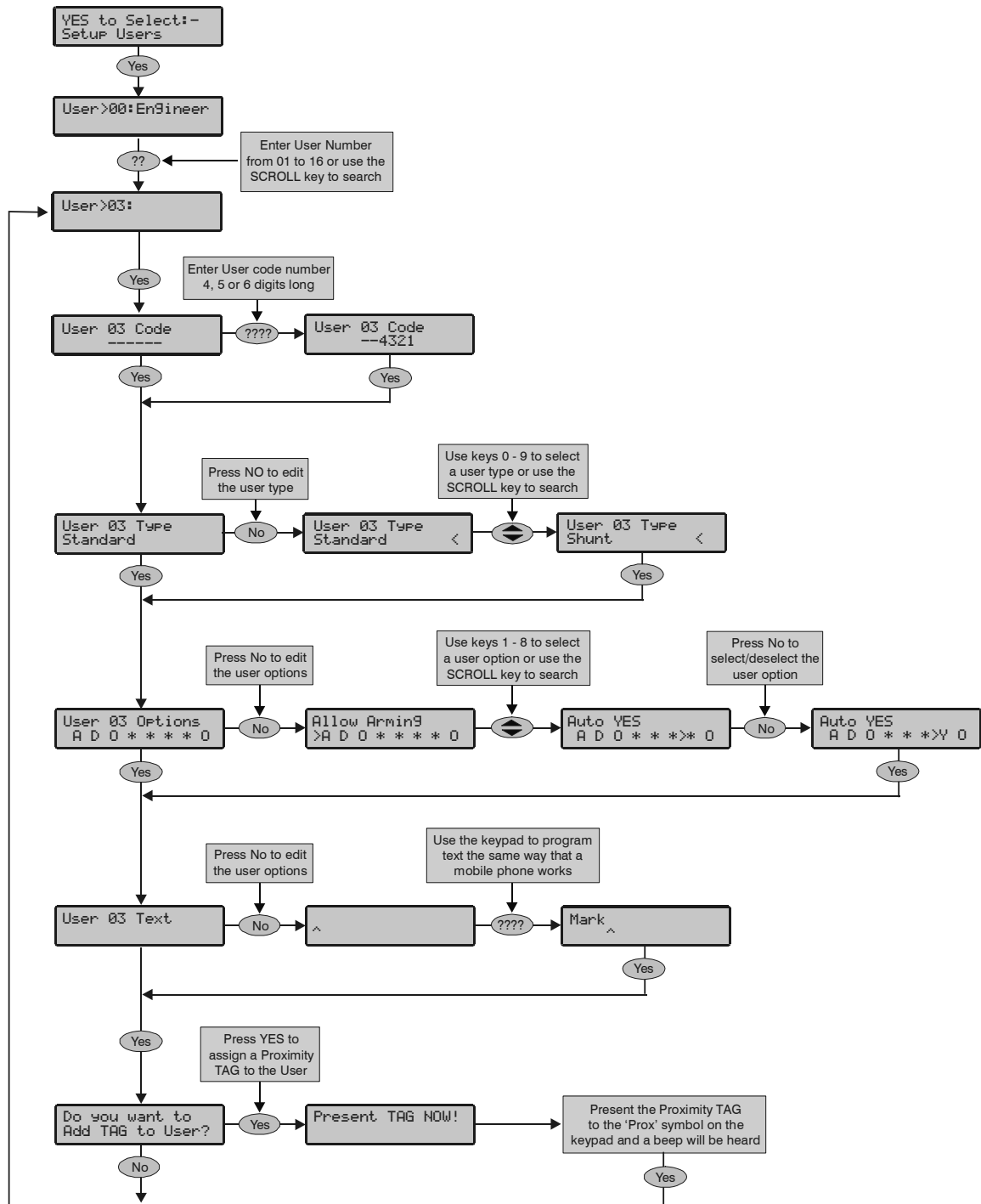

Adding New Users to the System

This section covers the alteration of existing users and the addition of new users to the system. The *Premier 24* can be assigned up to 15 users (plus Engineer).

Default User Codes

When the control panel is first powered up and the factory default settings are loaded (see page 23 for details), only the Engineer code and the Master User code exist.

The default Engineer user code is **1** **2** **3** **4**.



The Engineer is always User 00.

If the Engineer code has been lost or forgotten, it can normally be reset back to 1234 without having to default the entire system (see page 30 for details).

Resetting the Engineer code is only possible if the NVM has not been locked (see page 40 for details).

The default Master user code is **5** **6** **7** **8**.



The Master User is always User 01.

If the Master User code has been lost or forgotten, it can be reprogrammed by the Engineer in this menu.

Programming New Users

Each User code on the system is made up of the following elements **1**, **2** or **6**, **3** and **4**, these are essential for the code/TAG to function correctly, item **5** is optional.

25 User Number

When users are assigned to the system, they need to be identified by the control panel. Each user is identified as Users 01, 02, 03 etc. User 01 is always the Master User.

25 User Code

This is a unique 4, 5 or 6 digit code number that is assigned to a user. The system will allow a mixture of different length User codes. The User code must be entered at a keypad to operate the alarm system.

25 User Types

The User type determines which options the user can access i.e. Setup Users, System Tests etc.

4. User Options

The User Options determines which functions are available to the user i.e. arming, disarming, omitting etc.

5. User Name Text

Each user can be assigned up to 8 characters of name text. The name text is displayed whenever a code is entered and also when reading the log, making identification of people using the alarm easier.

6. Proximity TAG

As well as or instead of operating the alarm system with a code number, it is also possible to operate it by presenting a Proximity TAG to the keypad (this requires a Proximity keypad).

User Types

The User type determines which functions are available to the user i.e. arming, disarming etc. In addition, the User type also determines which options the user can access i.e. Setup Users etc. The following User types are available:

0: Engineer

Engineers can arm, disarm, omit zones, silence alarms and reset alarms. In addition, Engineers can access the Programming Menu and all User menu options. Engineers can also change their own User codes and assign new users to the system.



The default Engineer User type (User 00) can assign any User types to the system.

Engineers can only disarm the system if it was armed using an Engineer code. They cannot disarm the system if it was armed with a User code.

1: Master

Master users can arm, disarm, omit zones, silence alarms and reset alarms. In addition, Master users can access all User menu options. Master users can also change their own User codes and assign new users to the system. The Master user will also activate any output programmed as 'Door Strike'.

2: Manager

Manager users can arm, disarm, omit zones, silence alarms and reset alarms. In addition, Manager users can access all User menu options except Setup Users. Manager users can also change their own User codes.

3: Standard

Standard users can arm, disarm, omit zones, silence alarms and reset alarms. In addition, Standard users can access all User menu options except for Setup Users, System Tests, and Change Timers. Standard users can also change their own User codes.

4: Shunt

Shunt users are able to omit and reinstate any zone that has been programmed as 'Shunable'.

5: Duress

Duress users behave the same way as Standard users. However, Duress users will activate any outputs programmed as 'Panic Alarm' or 'Duress' whenever their code is entered.

6: Reset Only

Reset Only users can only disarm following an alarm and then reset and rearm the alarm again.

7: Door Strike





Door Strike users have no access to User functions or Menu options. However, Door Strike users will activate any outputs programmed as 'Door Strike' whenever their code is entered (see page 52 for details).

User Options

This menu is only displayed if the Custom User type is selected (see page 69 for details).

This menu defines which options are available to the user when their code is entered.

Some of the following options may not always be selectable or de-selectable.

Press  to scroll through the options and press  to select them or use keys  -  ('Letter' = option IS selected, 'Star' = option is NOT selected).

The following options are available:

A – Arming

The selected user can be armed.

D – Disarming

The selected user can be disarmed.

O – Omitting

The selected user can omit zones providing that they have the 'omit' attribute assigned to them (see page 33 for details).

T – Lock TAG = PGM2

The Users TAG is disabled whenever PGM2 is active.

C – Lock Code = PGM3

The Users code is disabled whenever PGM3 is active (default = during the Full Arm Entry mode).

U – Lock User = PGM4

The Users TAG and Code is disabled whenever PGM4 is active (default = Control Timer 4).

Y – Auto 'YES'

After a User code has been entered, pressing the  key to confirm the next action is not required.

O – Open/Close

The selected user will report open (disarm) and close (arm) events to an Alarm Receiving Centre every time they arm or disarm.

User Name Text

Each user can be assigned up to 8 characters of name text. This can be beneficial when reading the log, as identification of people is made easier.



Text is programmed in a similar way to mobile phones. Select characters by pressing the corresponding key the appropriate number of times (to select a character on the same key, press the  key to move the cursor along).

Programming Proximity TAGS

- To program TAGS proceed as follows:

Ensure that Setup Users is selected, the display should look like this:

```
Setup Users
Enter User --
```

Select a user   then press 

```
Do you want to
Add TAG to User?
```

Press 

```
Present TAG NOW !
```

Present the TAG to the 'Prox' symbol on the keypad

(A confirmation tone will be heard)

Press 

Press  to exit the menu

The display will return to normal.



Deleting User Codes

Deleting Users

- To delete User codes proceed as follows:

Ensure that Setup Users is selected, the display should look like this:

```
Setup Users
Enter User --
```

Select a user   then press 

```
Enter User Code>
-----
```

Press 

```
Do you want to
DELETE User 15
```

Press  to confirm deletion of the selected User code

Press 

Press  to exit the menu

The display will return to normal.

Available Options

The table below shows the options that are available to each user.

User Options								
	Code Type							
Options	Engineer	Master	Manager	Standard	Shunt	Duress	Reset Only	Door Strike
Arming	✓	✓	✓	✓		✓		
Disarming	✓	✓	✓	✓		✓		
Omitting	✓	✓	✓	✓				
Lock by PGM2								
Lock by PGM3								
Lock by PGM4								
Auto YES								
Open/Close	✓	✓	✓	✓	✓	✓	✓	

Arming Menu								
	Code Type							
Options	Engineer	Master	Manager	Standard	Shunt	Duress	Reset Only	Door Strike
Enable Chime	✓	✓	✓	✓		✓		
View Zones	✓	✓	✓	✓		✓		
Door Strike								✓

User Menu								
	Code Type							
Options	Engineer	Master	Manager	Standard	Shunt	Duress	Reset Only	Door Strike
View Event Log	✓	✓	✓	✓			✓	
Change Code	✓	✓	✓	✓				
Chime Zones	✓	✓	✓					
Bell Test	✓	✓	✓					
Walk Test	✓	✓	✓					
Enable Engineer	✓	✓	✓	✓				
Program Time	✓	✓						
Program Date	✓	✓						
Setup Users	✓	✓						
Alter Part Arms	✓	✓						
Call Rem. PC	✓	✓	✓	✓				
Edit Phone No's	✓	✓						

Engineer Menu								
	Code Type							
Options	Engineer	Master	Manager	Standard	Shunt	Duress	Reset Only	Door Strike
Engineer Program	✓							

6.9 Engineer Utilities

View Event Log

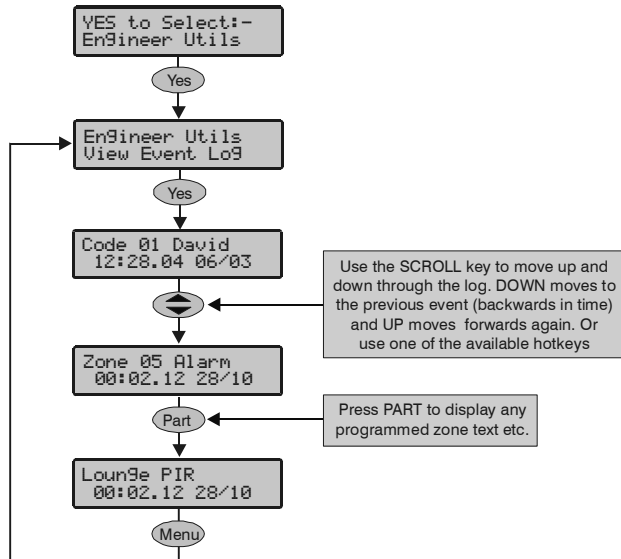

The control panel has an Event Log, that is time and date stamped. This log records all events that occur on the system, i.e. Users entering their codes to arm or disarm, alarm events, failures to arm etc.

Event Log Hotkeys

When viewing the system log there are 8 hotkeys available. These hotkeys allow certain events to be found easier without the need for searching.

The following hotkeys are available:

- ① = Priority Alarms (PA, Fire etc.)
- ②_{abc} = Normal Alarms (Guard, 24hr, Entry/Exit etc.)
- ③_{def} = Opens and Closings (Arm, Disarm etc.)
- ④_{ghi} = Omits and Reinstates (Zone Omits etc.)
- ⑤_{jkl} = Maintenance (System Tests, Engineer Program etc.)
- ⑥_{mno} = Tamperers (Zone, Bell, Aux etc.)
- ⑦_{pqr} = Test Calls (Communicator Active, successful etc.)
- ⑧_{rst} = Entry/Exit (Entry and Exit Procedures)
- ⑨ = User Codes (User codes being used)

Event Log Descriptions

Log Event	Description
KSW ### Active	A Keyswitch zone type has been activated (zone number ###)
RKP #,# MEDICAL	A Medical alarm (7 & 9) has occurred from keypad number #,#
RKP #,# FIRE	A Fire alarm (4 & 6) has occurred from keypad number #,#
RKP AUD PA #,#	An Audible PA alarm (1 & 3) has occurred from keypad number #,#
RKP SIL PA #,#	A Silent PA alarm (1 & 3) has occurred from keypad number #,#
DURESS	User ## has entered a Duress Code at a keypad
ALARM Active	An Intruder alarm signal has been activated
BELL Active	The Bell output has been activated
REARM LOCK ###	Zone ### has locked out after reaching its re-arm limit (after causing an alarm)
USER ##	User ## has entered their code
EXIT	The Exit mode has been started
ARMING FAILED	A Exit Error-Arm Fail has occurred
ENTRY	The Entry mode has been started
ARMED WITH L/F	The system has been armed with a Line Fault condition present
Armed	The system has been armed
Disarmed	The system has been disarmed
PART Armed	The system has been Part Armed
TIME Armed	The system was armed automatically using one of the control timers
TIME Disarmed	The system was disarmed automatically using one of the control timers
DEFERRED	The automatic arming mode was deferred
ALARM ABORT	An Open After Alarm-Abort has occurred
REMOTE Armed	The system was armed using the <i>Wintex UDL</i> software
REMOTE Disarmed	The system was disarmed using the <i>Wintex UDL</i> software
QUICK Armed	Quick Arm from keypad #,#
RECENT Armed	The system has been armed recently

Log Event	Description
#, # RESET -	The system has been reset using keypad #, # following an Intruder alarm
Engineer Reset	A reset has been performed using an Engineers code
Anti-Code Reset	A reset has been performed using the Anti-code reset procedure
Remote Reset	A reset has been performed using the 'Remote Reset' input
Key switch Reset	A reset has been performed using a key switch
User Reset	A reset has been performed using a User code
EXP #, # Reset	A reset has been performed using the input on expander #, # (programmed as reset)
Remote PC Reset	A reset has been performed by the remote download PC
FUSE #, # FAIL	The Auxiliary 12V Fuse/PTC in device #, # has failed
AC POWER	The control panel has registered a AC Mains failure
LOW BAT	The control panel has registered a low battery condition
POWERED UP	System Power Up (without doing a factory restart)
BELL FUSE	The control panel Bell Fuse has failed
LINE FLT	There is a problem with the telephone line
Panel Line Fault	The control panel line fault input has been activated
Com??? Line Fault	The Com300, 2400 or ISDN has detected a line fault
COMS FAILED	The Com300 or Com2400 has failed to report to the Alarm Receiving Centre
DOWNLOAD START	An Upload/Download has been initiated
DOWNLOAD END	The Upload/Download has finished
LOG ALERT	80% of the Event Log has filled (since the last Upload/Download)
DATE CHANGED	The control panel Time has been changed
TIME CHANGED	The control panel Date has been changed
PROG. START	An Engineer code has been entered
PROG. END	The Engineer has logged out of the Programming menu
BOX LID	The control panel lid has been removed causing a Tamper alarm
BELL #, # Tamper	A Bell Tamper input from device #, # has been activated
AUX #, # Tamper	An Auxiliary Tamper input from device #, # has been activated
EXP #, # Tamper	The cover of expander #, # has been removed
RKP #, # Tamper	The cover of keypad #, # has been removed
RKP #, # LOST	Keypad ## has been lost from the network
EXP #, # LOST	Expander ## has been lost from the network
FIRE ### Active	Zone ### (programmed as Fire Alarm) has caused an alarm
Zone ### Tamper	Zone ### has caused a Tamper alarm
Zone ### Active	Zone ### has been activated
Zone ### Restore	Zone ### has restored to its normal condition
Zone ### Omitted	Zone ### has been omitted
Zone ### Un-Omit	Zone ### has been reinstated
Zone ### Test Start	Zone ### has been put on test
Zone ### Test End	Zone ### has been removed from test
RKP LOCKED #, #	Keypad #, # has been locked out from too many invalid key presses
CODE #, #	Too many invalid key presses have caused a tamper alarm from keypad #, #
TEST FAIL ###)	Zone ### has failed its Soak test
MANUAL TEST CALL	A Manual test call has been initiated
AUTO TEST CALL	An Automatic test call has been initiated
WALK	The Walk Test mode has been initiated
TESTED ###	Zone ### has been tested
DEFAULTS LOADED	The factory default values have been loaded into memory
FIRST KNOCK ###	Zone ### (which is programmed as double knock) has activated for the first time
CURRUPT EVENT	No event has been stored in memory

Do Bell Test

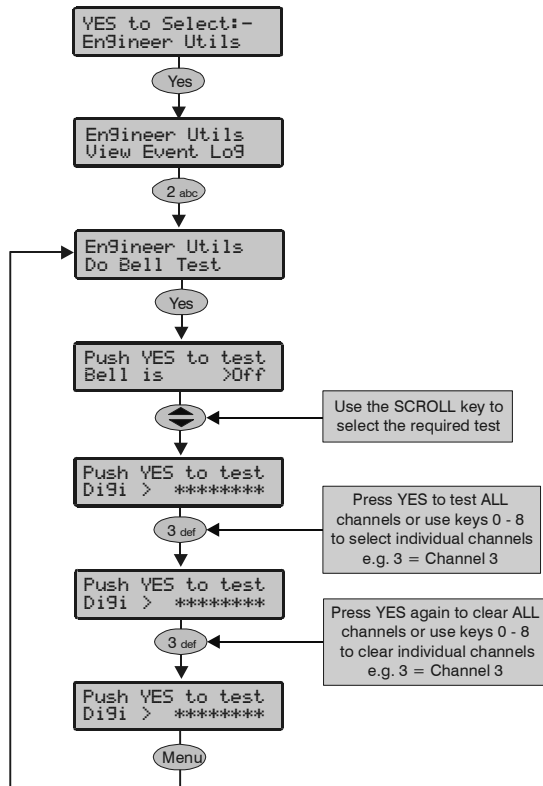

This option allows the Bell, Speaker and various control panel outputs to be tested.

The following outputs can be individually tested:

Test Bell	The Bell output
Test Strobe	The Strobe output
Test Speaker	The Speaker output
LCD Display	The LCD keypad display
User Outputs	Any outputs that have the 'User Test' attribute (see page 53 for details).
Test Panel	The 6 panel outputs
Test Comm	The 8 plug on digi outputs

Do Walk Test

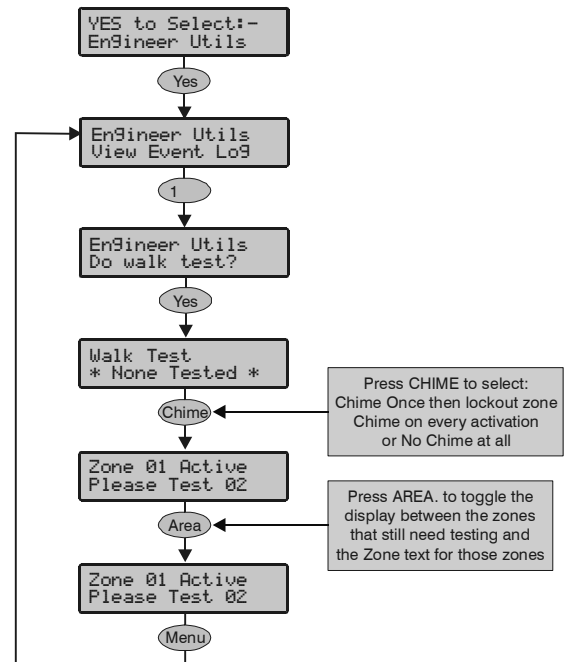

Any of the zones on the system can be walk tested to ensure that they operate correctly. A walk test can only be performed when the system is disarmed.



Once a zone has been activated it will not generate a chime tone again. If however the **Chime** key is pressed, a zone will chime every time it is activated.

Pressing the **Area** key will display the zone text associated with the zones.

View Zone Status

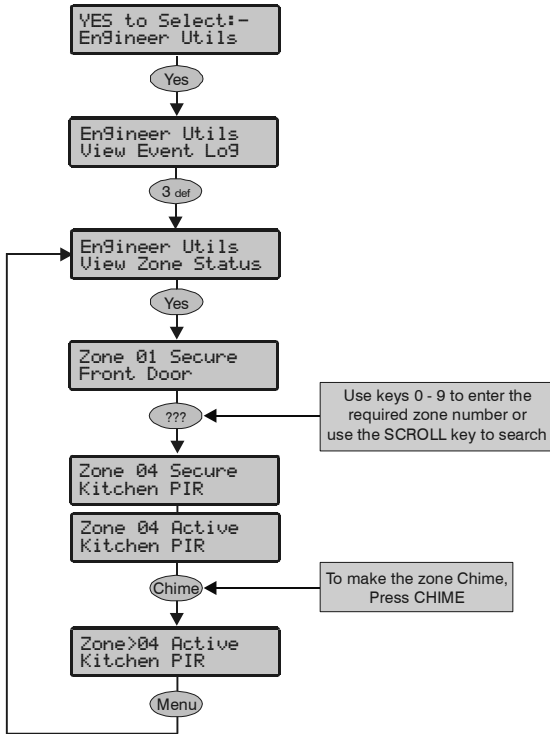

This option can be used to view the status of any zone on the system to see whether it is 'Active', 'Secure', 'Tampered' or 'Shorted'. The selected zone can also be temporarily disabled (zone and tamper) to allow the zone to be worked on or made to chime every time it is activated.

NOTE When leaving the View Zone Status menu, all zones will be automatically reinstated and cleared of Chime.

View Version No

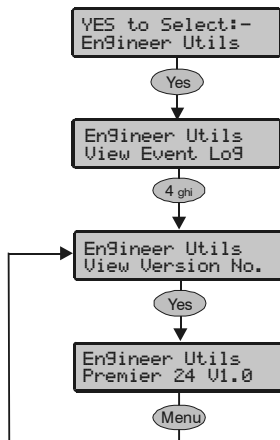

This option allows the control panel software version and serial number to be viewed.

Confirm Devices

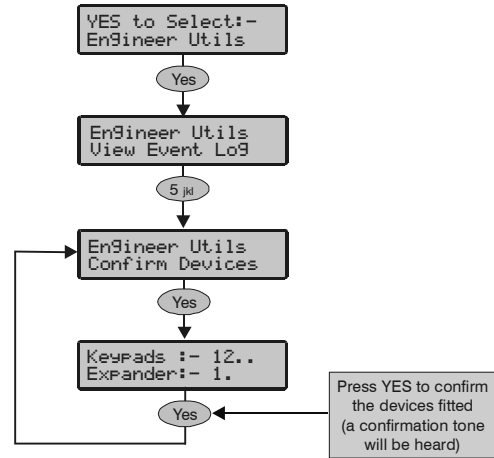

This option allows the networks to be viewed to see what devices are connected and whether there are any problems. Whenever new devices are added to the system, the networks must be checked and confirmed.

NOTE If any devices are removed from the system, the networks must be rechecked and reconfirmed.

View RKP Status

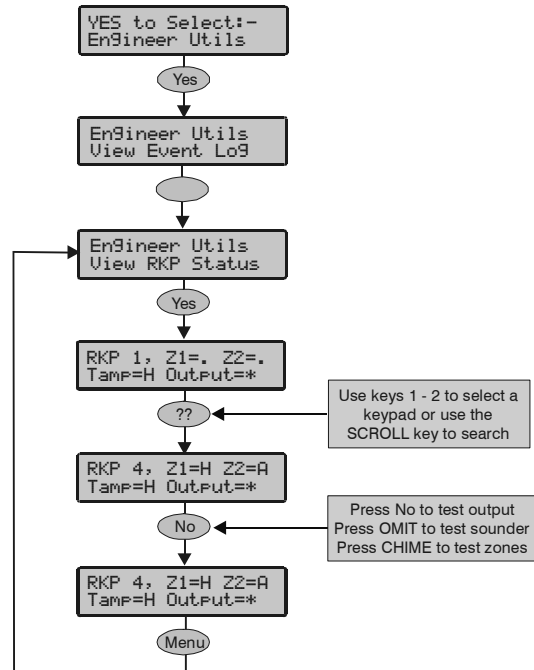

This option allows the status of the keypad, the zones and the output to be viewed.

Check Exp. Status

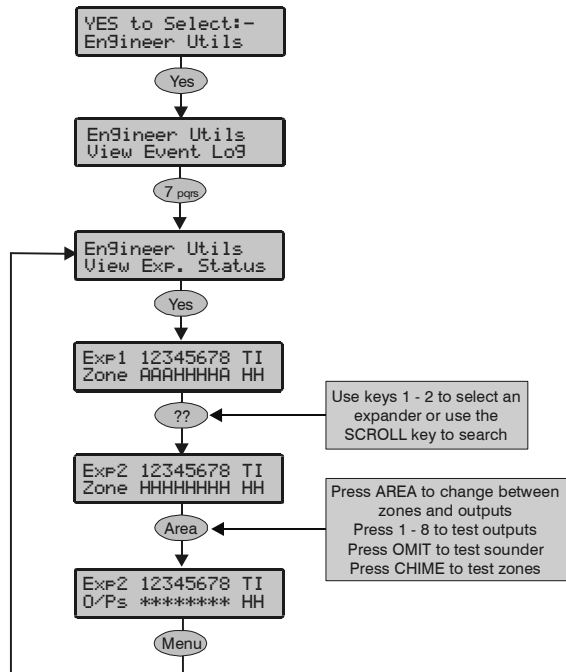

This option allows the status of the expander, the zones, voltage/inputs and outputs to be viewed.

Set System Date

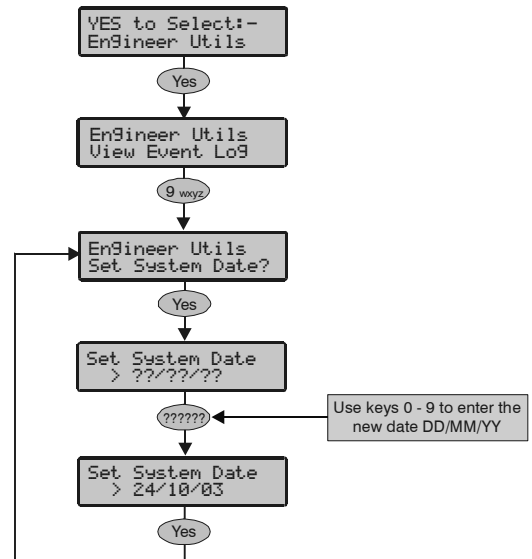

The control panel has a real time clock that is used to date and time stamp events that are recorded within the system log. The option allows you to set the control panel date.

Set System Time

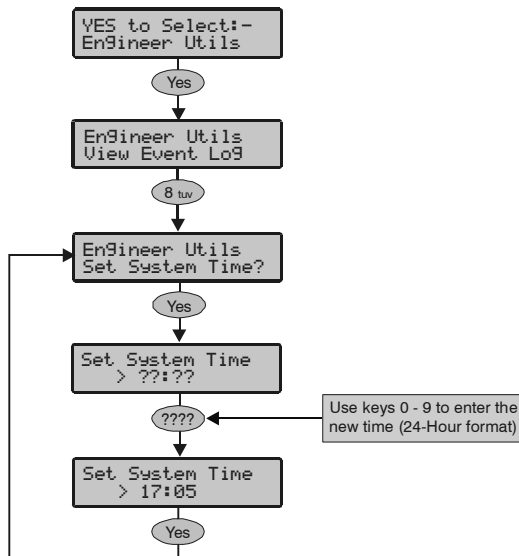

The control panel has a real time clock that is used to date and time stamp events that are recorded within the system log. The option allows you to set the control panel time.

Change Eng. Code

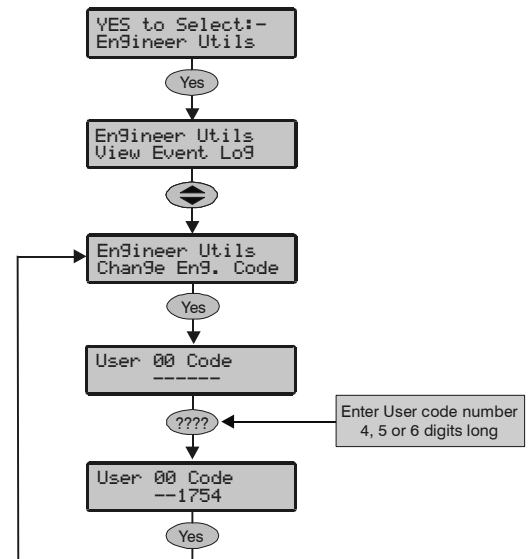

This option allows the Engineer code (User 00) to be changed. This code can be 4, 5 or 6 digits in length. The system will allow a mixture of different length User codes.

6.10 Programming Part Arms

Alter Part Arms

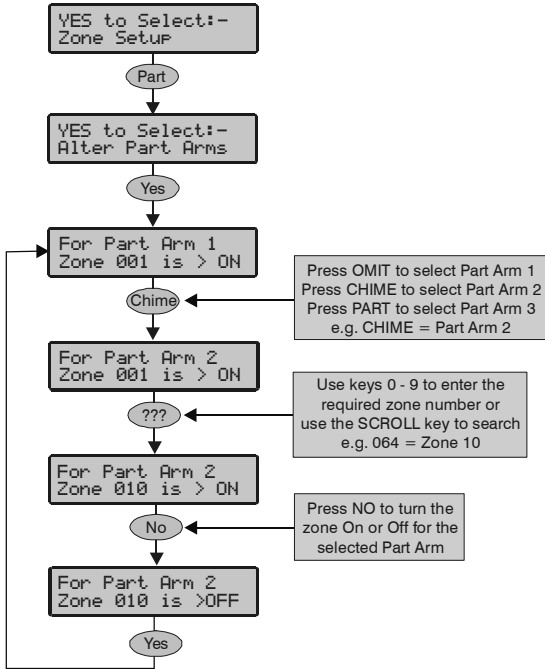

The system can have up to 3 Part Arms.

When Part Arm 1, 2 or 3 is selected, pre-programmed zones are omitted to allow access to certain parts of the building.

7. Specifications

Control Panel

Power supply

Mains Supply Voltage:	230VAC ($\pm 10\%$)
Maximum Total Current Rating	
16.5V _{AC} , 40VA transformer:	1.5ADC
Ripple	<5%
Rechargeable Battery Capacity	1.2Ah to 17Ah

Electrical

Current Consumption

Quiescent	<50mA
Alarm (with speaker)	<150mA

Fuses

Mains (1.0ADC)	125mA, 250V, 20mm
Mains (1.5ADC)	500mA, 250V, 20mm
Battery	1.6A, 250V PTC
Auxiliary	900mA, 250V PTC
Bell	900mA, 250V PTC
Network 1	900mA, 250V PTC

Rechargeable Battery Capacity	1.2Ah to 17Ah
--------------------------------------	---------------

Remote Keypads	Up to four
-----------------------	------------

Expanders	2 8XP OR 1 8XE+ 1 8XP
------------------	-----------------------------

Output Modules	1
-----------------------	---

Zones	8 expandable to 24
--------------	--------------------

EOL Resistor Value	2k2 EOL & 4k7 contact OR 3k3 EOL & 3k3 Contact
---------------------------	--

Panel Outputs

O/P 1	100mA switched to 0V
O/P 2	100mA switched to 0V
O/P 3	100mA switched to 0V
O/P 4	100mA switched to 0V
O/P 5	100mA switched to 0V
O/P 6	100mA switched to 0V
PGM1	100mA switched to 0V

Speaker Output	Minimum load 8 Ω
-----------------------	-------------------------

Network

+	+12V Power
-	0V Power
T	Transmitted Data
R	Received Data

Environmental

Operating Temperature	-10°C (+14°F) to +50°C (+122°F)
Storage Temperature	-20°C (-4°F) to +60°C (+140°F)
Maximum Humidity	95% non-condensing
EMC Environment	Residential Commercial Light Industrial Industrial

Physical

Dimensions	305mm x 405mm x 100mm
Material	2mm Steel
Battery Compartment	Up to two 12V 7.0Ah batteries or one 12V 17Ah battery
Packed Weight	5.5 Kg

Remote Keypads

Electrical

Operating Voltage 10 – 13.7VDC

Current Consumption

Quiescent >35mA
When Fully Backlit >85mA

Keypad Type

Premier LCD 32 Character standard screen LCD
Premier LCDL 32 Character large screen LCD
Premier LCD/LCDP LCD with built in Prox Reader
Premier LCDL/LCDP LCDL with built in Prox Reader

Zones

Number 2
EOL Resistor Value 2k2 EOL & 4k7 Contact

Speaker Output

O/P 1 500mA switched to 12V

Network

4-wire standard 7/0.2 alarm cable up to 250m Star, Daisy Chain or any combination of the two

Back Lighting

Fully adjustable

Speaker Output (LCDL/LCDLP) Minimum load 8Ω

Speaker Volume (LCDL/LCDLP) Fully adjustable

Proximity Reader (LCDP/LCDLP) Tag

Environmental

Operating Temperature -10°C (+14°F) to +50°C (+122°F)

Storage Temperature -20°C (-4°F) to +60°C (+140°F)

Maximum Humidity 95% non-condensing

EMC Environment Residential
Commercial
Light Industrial
Industrial

Physical

Dimensions 140mm x 115mm x 30mm

Packed Weight 260g Approx.

Zone Expanders

Electrical

Operating Voltage 9 – 13.7VDC

Current Consumption

Quiescent >65mA
In alarm with speaker >320mA

Network

4-wire standard 7/0.2 alarm cable up to 250m Star, Daisy Chain or any combination of the two

Zones

Number 8
EOL Resistor Value 2k2 EOL & 4k7 Contact

Speaker Output

Minimum load 8Ω

Outputs

O/P 1 100mA switched to 0V
O/P 2 100mA switched to 0V
O/P 3 100mA switched to 0V
O/P 4 100mA switched to 0V
O/P 5 100mA switched to 0V
O/P 6 100mA switched to 0V
O/P 7 100mA switched to 0V
O/P 8 100mA switched to 0V

Environmental

Operating Temperature -10°C (+14°F) to +50°C (+122°F)

Storage Temperature -20°C (-4°F) to +60°C (+140°F)

Maximum Humidity 95% non-condensing

EMC Environment Residential
Commercial
Light Industrial
Industrial

Physical

Dimensions 150mm x 120mm x 30mm

Packed Weight 200g Approx.

Output Expanders

Electrical

Operating Voltage	9 – 13.7Vdc
Current Consumption	
Quiescent	>35mA
Network	4-wire standard 7/0.2 alarm cable up to 250m Star, Daisy Chain or any combination of the two

Bank 1 Outputs

O/P 1	100mA switched to 0V
O/P 2	100mA switched to 0V
O/P 3	100mA switched to 0V
O/P 4	100mA switched to 0V
O/P 5	100mA switched to 0V
O/P 6	100mA switched to 0V
O/P 7	100mA switched to 0V
O/P 8	100mA switched to 0V

Bank 2 Outputs

O/P 1	100mA switched to 0V
O/P 2	100mA switched to 0V
O/P 3	100mA switched to 0V
O/P 4	100mA switched to 0V
O/P 5	100mA switched to 0V
O/P 6	100mA switched to 0V
O/P 7	100mA switched to 0V
O/P 8	100mA switched to 0V

Environmental

Operating Temperature	-10°C (+14°F) to +50°C (+122°F)
Storage Temperature	-20°C (-4°F) to +60°C (+140°F)
Maximum Humidity	95% non-condensing
EMC Environment	Residential Commercial Light Industrial Industrial

Physical

Dimensions	150mm x 120mm x 30mm
Packed Weight	200g Approx.

Communicators

Electrical

Operating Voltage	9 – 13.7Vdc
Current Consumption	
Quiescent	>25mA
When Active	>80mA
Com300 Protocol	Fast Format Contact ID SIA Level II EasyCom Pager V.21 Modem (300 baud)
Com2400 Protocol	Fast Format Contact ID SIA Level II EasyCom Pager SMS Messaging V.21 Modem (300-baud) V.22 Modem (2400-baud)
ComISDN Protocol	Fast Format Contact ID SIA Level II EasyCom Pager SMS Messaging V.21 Modem (300-baud) V.34 Modem (19200 baud)

Telephone Numbers	6 (up to 24 digits each)
Dialling Formats	Pulse or DTMF
REN	1
Approval	CTR21

Environmental

Operating Temperature	-10°C (+14°F) to +50°C (+122°F)
Storage Temperature	-20°C (-4°F) to +60°C (+140°F)
Maximum Humidity	95% non-condensing
EMC Environment	Residential Commercial Light Industrial Industrial

Physical

Dimensions	150mm x 120mm x 30mm
Packed Weight	50g Approx.

Standards

Conforms to European Union (EU) Low Voltage Directive (LVD) 73/23/EEC and Electro-Magnetic Compatibility (EMC) Directive 89/336/EEC.

The CE mark indicates that this product complies with the European requirements for safety, health, environmental and customer protection.

This equipment is designed to enable an intruder alarm system in which it is installed to comply with the requirements of security grades 1, 2 or 3 of EN 50131-1 and EN 50131-6 and is suitable for installation in any indoor environment.

Warranty

All Texecom products are designed for reliable, trouble free operation. Quality is carefully monitored by extensive computerised testing. As a result the control panel is covered by a two-year warranty against defects in materials or workmanship.

As the control panel is not a complete alarm system but only a part thereof, Texecom cannot accept responsibility or liability for any damages whatsoever based on a claim that the control panel failed to function correctly.

Due to our policy of continuous improvements Texecom reserve the right to change specification without prior notice.

The *Premier 24* is protected by Community Registration Design Number: 000057211-0001. *Premier* Keypads and Expanders are protected by UK & International Registered Design. Registered Design Numbers: 2089016 and 3004996.

Premier is a trademark of Texecom.

This page is intentionally blank.

8. Quick Reference Guide

0 _{...}	Log Off Engineer
Yes	Press Yes to log out of the Engineer Programming menu

1	Zone Setup																	
Yes	Zone Types	<p>Use 1 - 8_{...} to enter zone number, No to edit, 0_{...} - 9_{...} or ↕ to select a zone type, Yes to accept</p> <table style="width: 100%; border: none;"> <tr> <td style="width: 50%;">0_{...} Not Used</td> <td style="width: 50%;">8_{sv} PA Silent</td> </tr> <tr> <td>1 Entry/Exit 1</td> <td>9_{resp} Fire</td> </tr> <tr> <td>2_{abc} Entry/Exit 2</td> <td>↕ 24Hr Gas</td> </tr> <tr> <td>3_{def} Guard</td> <td>↕ Auxiliary</td> </tr> <tr> <td>4_{ghi} Guard Access</td> <td>↕ Tamper</td> </tr> <tr> <td>5_{jit} 24Hr Audible</td> <td>↕ Exit Terminator</td> </tr> <tr> <td>6_{mn} Trouble</td> <td>↕ Key Switch</td> </tr> <tr> <td>7_{opq} PA Audible</td> <td></td> </tr> </table>	0 _{...} Not Used	8 _{sv} PA Silent	1 Entry/Exit 1	9 _{resp} Fire	2 _{abc} Entry/Exit 2	↕ 24Hr Gas	3 _{def} Guard	↕ Auxiliary	4 _{ghi} Guard Access	↕ Tamper	5 _{jit} 24Hr Audible	↕ Exit Terminator	6 _{mn} Trouble	↕ Key Switch	7 _{opq} PA Audible	
0 _{...} Not Used	8 _{sv} PA Silent																	
1 Entry/Exit 1	9 _{resp} Fire																	
2 _{abc} Entry/Exit 2	↕ 24Hr Gas																	
3 _{def} Guard	↕ Auxiliary																	
4 _{ghi} Guard Access	↕ Tamper																	
5 _{jit} 24Hr Audible	↕ Exit Terminator																	
6 _{mn} Trouble	↕ Key Switch																	
7 _{opq} PA Audible																		
Yes	Zone Attributes 1	<p>Press No to edit, 1 - 8_{sv} to select an attribute, Yes to accept</p> <table style="width: 100%; border: none;"> <tr> <td style="width: 50%;">1 O = Omittable</td> <td style="width: 50%;">5_{jit} 3 = Part 3 Omit</td> </tr> <tr> <td>2_{abc} F = Force Omit</td> <td>6_{mn} 1 = Chime 1</td> </tr> <tr> <td>3_{def} 1 = Part 1 Omit</td> <td>7_{opq} 2 = Chime 2</td> </tr> <tr> <td>4_{ghi} 2 = Part 2 Omit</td> <td>8_{sv} G = Guard</td> </tr> </table>	1 O = Omittable	5 _{jit} 3 = Part 3 Omit	2 _{abc} F = Force Omit	6 _{mn} 1 = Chime 1	3 _{def} 1 = Part 1 Omit	7 _{opq} 2 = Chime 2	4 _{ghi} 2 = Part 2 Omit	8 _{sv} G = Guard								
1 O = Omittable	5 _{jit} 3 = Part 3 Omit																	
2 _{abc} F = Force Omit	6 _{mn} 1 = Chime 1																	
3 _{def} 1 = Part 1 Omit	7 _{opq} 2 = Chime 2																	
4 _{ghi} 2 = Part 2 Omit	8 _{sv} G = Guard																	
Yes	Zone Attributes 2	<p>Press No to edit, 1 - 8_{sv} to select an attribute, Yes to accept</p> <table style="width: 100%; border: none;"> <tr> <td style="width: 50%;">1 D = Double Knock</td> <td style="width: 50%;">5_{jit} R = Reset</td> </tr> <tr> <td>2_{abc} S = Shunt Group</td> <td>6_{mn} I = Inverted</td> </tr> <tr> <td>3_{def} T = Soak Test</td> <td>7_{opq} Q = Quick Resp.</td> </tr> <tr> <td>4_{ghi} F = Activity</td> <td>8_{sv} ! = Shock</td> </tr> </table>	1 D = Double Knock	5 _{jit} R = Reset	2 _{abc} S = Shunt Group	6 _{mn} I = Inverted	3 _{def} T = Soak Test	7 _{opq} Q = Quick Resp.	4 _{ghi} F = Activity	8 _{sv} ! = Shock								
1 D = Double Knock	5 _{jit} R = Reset																	
2 _{abc} S = Shunt Group	6 _{mn} I = Inverted																	
3 _{def} T = Soak Test	7 _{opq} Q = Quick Resp.																	
4 _{ghi} F = Activity	8 _{sv} ! = Shock																	
Yes	Key Attributes (only applicable for keyswitch zone types)	<p>Press No to edit, 1 - 5_{jit} to select an attribute, Yes to accept</p> <table style="width: 100%; border: none;"> <tr> <td style="width: 50%;">1 I = Instant Arming</td> <td style="width: 50%;">5_{jit} S = Silent Arming</td> </tr> <tr> <td>2_{abc} s = Shunt Key</td> <td>6_{mn} I = Inverted</td> </tr> <tr> <td>3_{def} F = Full Disable</td> <td>7_{opq} Q = Quick Resp.</td> </tr> <tr> <td>4_{ghi} D = Disarm Only</td> <td>8_{sv} L = Latching</td> </tr> </table>	1 I = Instant Arming	5 _{jit} S = Silent Arming	2 _{abc} s = Shunt Key	6 _{mn} I = Inverted	3 _{def} F = Full Disable	7 _{opq} Q = Quick Resp.	4 _{ghi} D = Disarm Only	8 _{sv} L = Latching								
1 I = Instant Arming	5 _{jit} S = Silent Arming																	
2 _{abc} s = Shunt Key	6 _{mn} I = Inverted																	
3 _{def} F = Full Disable	7 _{opq} Q = Quick Resp.																	
4 _{ghi} D = Disarm Only	8 _{sv} L = Latching																	
Yes	Zone Text	<p>Press No to edit, 0_{...} - 9_{...} to select characters (press the required key the appropriate number of times), Yes to accept</p> <table style="width: 100%; border: none;"> <tr> <td style="width: 33%;">1 . , ? ! 1 @ " -</td> <td style="width: 33%;">5_{jit} J K L 5</td> <td style="width: 33%;">9_{resp} W X Y Z 9</td> </tr> <tr> <td>2_{abc} A B C 2</td> <td>6_{mn} M N O 6</td> <td>0_{...} 0 _</td> </tr> <tr> <td>3_{def} D E F 3</td> <td>7_{opq} P Q R S 7</td> <td>↕ Move Cursor</td> </tr> <tr> <td>4_{ghi} G H I 4</td> <td>8_{sv} T U V 8</td> <td></td> </tr> </table>	1 . , ? ! 1 @ " -	5 _{jit} J K L 5	9 _{resp} W X Y Z 9	2 _{abc} A B C 2	6 _{mn} M N O 6	0 _{...} 0 _	3 _{def} D E F 3	7 _{opq} P Q R S 7	↕ Move Cursor	4 _{ghi} G H I 4	8 _{sv} T U V 8					
1 . , ? ! 1 @ " -	5 _{jit} J K L 5	9 _{resp} W X Y Z 9																
2 _{abc} A B C 2	6 _{mn} M N O 6	0 _{...} 0 _																
3 _{def} D E F 3	7 _{opq} P Q R S 7	↕ Move Cursor																
4 _{ghi} G H I 4	8 _{sv} T U V 8																	
Yes	Wiring Type	<p>Press No to alter wiring type, Yes to accept</p> <table style="width: 100%; border: none;"> <tr> <td style="width: 50%;">0_{...} Normally Closed</td> <td style="width: 50%;">2_{abc} Double EOL</td> </tr> <tr> <td>1 Normally Open</td> <td></td> </tr> </table>	0 _{...} Normally Closed	2 _{abc} Double EOL	1 Normally Open													
0 _{...} Normally Closed	2 _{abc} Double EOL																	
1 Normally Open																		

Arming Options	
2 _{abc}	Arming Options
0 _{...}	<p>Use <input type="button" value="↕"/> or <input type="button" value="Yes"/> to select a timer, 0_{...} - 9_{msg} to enter a value, <input type="button" value="Yes"/> to accept</p> <p>01: Exit Delay 04: 2nd Entry Delay 07: Coms Delay 02: Entry Delay 1 05: Bell Delay 08: Part Bell Delay 03: Entry Delay 2 06: Bell Duration</p>
1	<p>Use <input type="button" value="↕"/> to select full arm or part arm 1-3, 1 - 5_{su} to select arming an mode, <input type="button" value="Yes"/> to accept</p> <p>1 Entry/Exit 3_{def} Timed Exit 5_{su} Deferred 2_{abc} Exit Term. 4_{su} Instant</p>
5 _{su}	<p>Use <input type="button" value="↕"/> to select option 1 or 2, press <input type="button" value="No"/> to edit, 1 - 8_{sv} to select option, <input type="button" value="Yes"/> to accept</p> <p>Options 1 1 Auto Part Arm 4_{su} Time Arming CT1 7_{psp} Tamper Eng Reset 2_{abc} Part Arm Silent 5_{su} Alarm Eng Reset 8_{sv} Anti-code Reset 3_{def} Remote Arm/Disarm 6_{msg} Confirmation Reset</p> <p>Options 2 1 Arm With L/Fault 4_{su} Unarm Fire Coms 7_{psp} Confirm in Entry 2_{abc} Arm With AC Fail 5_{su} Unarm Tamper Coms 8_{sv} Conf. After Entry 3_{def} Part Arm Coms 6_{msg} Log Part Omits</p>

Global Options	
3 _{def}	Global Options
0 _{...}	<p>Use <input type="button" value="↕"/> to select a timer, 0_{...} - 9_{msg} to enter a value, <input type="button" value="Yes"/> to accept</p> <p>01: Exit Settle Time 06: Pulse Period 1 11: Soak Test Time 02: Double Knock Dly 07: Line Fault Delay 12: Service Interval 03: Activity Delay 08: AC Off Delay 13: Test Call Every 04: Abort Delay 09: Batt Test Period 14: Quick Response 05: Courtesy Time 10: Batt Test Time 15: Confirmation Dly</p>
1	<p>Use <input type="button" value="↕"/> to select an option, <input type="button" value="No"/> to change the option, <input type="button" value="Yes"/> to accept</p> <p>00: (No Bell/Bell on) Arm Fail 12: Code Tamp (Alarms/Locks) 01: Bell is an (SAB/SCB) 13: Zone Short=(Active/Tamper) 02: (Manual/Auto) BST/GMT 14: R/R=(Reset Only/Silence/RST) 03: (Leave/Remove) Omits 15: Test Call = (Timed/Timed) 04: Away (Override/Enforce) Delay 16: Batt Test = (Timed/Disarm) 05: NVM is (Unlocked/Locked) 17: Bell = (1st Alarm/2nd Alarm) 06: Engineer (Only/+ User) 18: SNDR = (1st Alarm/2nd Alarm) 07: Omit Tamper (NO/YES) 19: Abort = (Eng. Reset/User Reset) 08: (80/40) Column Printer 20: 8XE = (Zones 9-16/Tampers 1-8) 09: Activity Fault (View/Hide) 21: (2nd Zone /1st Zone) = Confirm 10: (Hide/View) Exit Errors 22: Access (No Conf./= Confirm) 11: (No/Enable) Code Tampers 23: EN50131 (Disabled/Enabled)</p>
2 _{abc}	<p>Use <input type="button" value="↕"/> to select an Option, 0_{...} - 9_{msg} to enter a value, <input type="button" value="Yes"/> to accept</p> <p>01: Advisory Volume 03: Number Of Re-Arms 02: Chime Volume 04: Anti-code Resets</p>
4 _{su}	<p>Use <input type="button" value="↕"/> to select a timer, 0_{...} - 9_{msg} to enter the 1st On time, <input type="button" value="Yes"/> to accept Use 1 - 7_{psp} to select the 1st On time days of operation, <input type="button" value="Yes"/> to accept Use 0_{...} - 9_{msg} to enter the 1st Off time, <input type="button" value="Yes"/> to accept Use 1 - 7_{psp} to select the 1st Off time days of operation, <input type="button" value="Yes"/> to accept</p>
5 _{su}	<p>Use <input type="button" value="↕"/> to select a message, 0_{...} - 9_{msg} to select characters (press the required key the appropriate number of times), <input type="button" value="Yes"/> to accept</p>
8 _{sv}	<p>Use <input type="button" value="↕"/> to select a tone type, <input type="button" value="No"/> to turn the tone on/off, <input type="button" value="Yes"/> to accept</p>

8 _{lv}		Setup Users		
Yes	User Code	Use 0 _{...} - 9 _{exp} to enter a code, Yes to accept		
Yes	User Types	Use 0 _{...} - 9 _{exp} to select a user type, Yes to accept		
		0 _{...} Engineer 3 _{def} Standard 6 _{mo} Reset Only		
		1 _{...} Master 4 _{gh} Shunt 7 _{pp} Door Strike		
2 _{abc} Manager 5 _{pl} Duress				
Yes	User Options 1 (only available to Custom users)	Press No to edit, \updownarrow to select an option, No to change option, Yes to accept		
		1 _{...} Arming 5 _{pl} Lock CODE by PGM3		
		2 _{abc} Disarming 6 _{mo} Lock USER by PGM4		
		3 _{def} Omitting 7 _{pp} Auto 'YES'		
		4 _{gh} Lock TAG by PGM2 8 _{lv} Send Open/Close		
Yes	User Text	Press No to edit, 0 _{...} - 9 _{exp} to select characters (press the required key the appropriate number of times), Yes to accept		
		1 _{...} . , ? ! 1 @ " - 5 _{pl} J K L 5 9 _{exp} W X Y Z 9		
		2 _{abc} A B C 2 6 _{mo} M N O 6 0 _{...} 0 _		
		3 _{def} D E F 3 7 _{pp} P Q R S 7 \updownarrow Move Cursor		
		4 _{gh} G H I 4 8 _{lv} T U V 8		

9 _{exp}		Engineer Utils
0 _{...}	View System Log	Use \updownarrow to move up and down through log (down moves back in time, up moves forward again), Part to show other information 1 - 8 _{lv} to find specific events
1	Do Bell Test	Use \updownarrow to select an option, use 1 - 8 _{lv} or Yes to activate outputs
		1: Test Bell 5: LCD Display
		2: Test Strobe 6: Test Panel
		3: Test Speaker 7: Test Comms
		4: User Outputs
2 _{abc}	Do Walk Test	Press Area to display zones that have been tested/still need testing, Chime to make zones Chime every time they are activated.
3 _{def}	View Zone Status	Use 0 _{...} - 9 _{exp} to enter zone number or use \updownarrow to search, Chime to walk test selected zone, Omit to omit zone temporarily
4 _{gh}	View Version No.	Press Yes to view hardware information
5 _{pl}	Confirm Devices	Use \updownarrow to select network, Yes to confirm Devices
6 _{mo}	Check RKP Status	Use 1 - 4 _{gh} to select keypad, No to test output, Omit to test sounder,
7 _{pp}	Check Exp. Status	Use 1 - 2 _{abc} to select expander, Area to display zones/outputs, Chime to test zones, Omit to test sounder, 1 - 8 _{lv} to test outputs
8 _{lv}	Set System Time	Use 0 _{...} - 9 _{exp} to enter time (24-hour format) H H M M, Yes to accept
9 _{exp}	Set System Date	Use 0 _{...} - 9 _{exp} to enter date D D M M Y Y, Yes to accept
\updownarrow	Change Eng Code	Use 0 _{...} - 9 _{exp} to enter a code, Yes to accept

Part		Alter Part Arms
		Press 0 _{...} - 9 _{exp} to enter zone number or use \updownarrow to search, Omit, Chime or Part to select Part Arms 1, 2 or 3
Omit	Part Arm 1	Chime Part Arm 2 Part Part Arm 3

Texecom

www.texe.com

Texecom Limited, Bradwood Court, St. Crispin Way, Haslingden, Lancashire BB4 4PW, England.

Technical Support:

Tel: +44 (0)1706 234833

Tel: +44 (0)1706 234811

Fax: +44 (0)1706 213187

© TEXECOM LTD. 2003

INS248-2